

Ø 190 mm, BACKWARD CURVED

AC CENTRIFUGAL FAN



**Features**

- **Materials:** Impeller – PA6+GF30  
Inlet ring – PA6+GF30  
Housing – sheet steel, painted grey
- **Direction of rotation:** clockwise, seen on rotor
- **Type of protection:** IP44
- **Insulation class:** B
- **Mode of operation:** continuous operation (S1)
- **Bearing:** ball bearings
- **Motor protection:** self-resetting TOP wired internally



**Technical data**

Model	Perform. curve	Nominal voltage [VAC]	Frequency [Hz]	Speed [RPM]	Power input max [W]	Current max [A]	Sound pres. level [dB(A)]	Perm. amb. temp. [°C]	Capacitor / Capacitor voltage [µF] / [VDB]	Electrical connection	Inlet ring
*L-B190A-2E-A01-01	I	230	50	2425	65	0.30	62	-25 ... +50	1.5/450	Type "A"/p. 39	p.38
	II	230	60	2530	80	0.35	64	-25 ... +50	1.5/450	Type "A"/p. 39	p.38
*L-B190A-2E-A02-01	III	230	50	2180	63	0.30	58	-25 ... +50	1.0/450	Type "A"/p. 39	p.38
	IV	230	60	2150	72	0.35	60	-25 ... +50	1.0/450	Type "A"/p. 39	p.38

**PERFORMANCE CURVES**

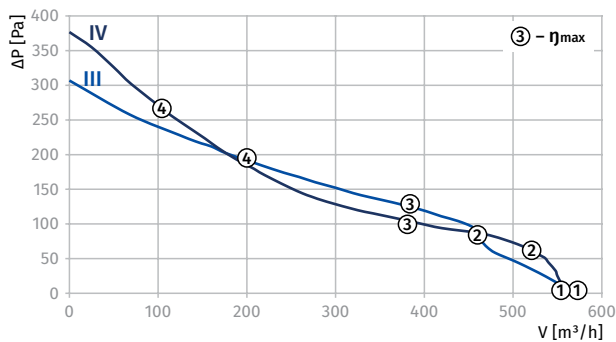
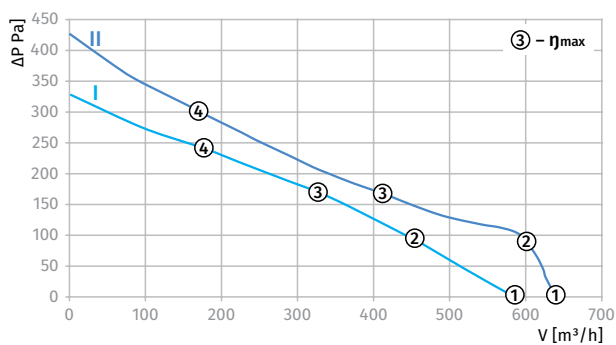

Curve	Point	n [RPM]	Pi [W]	I [A]
I	1	2560	60	0.27
	2	2500	62	0.28
	3	2425	65	0.29
	4	2500	62	0.28
II	1	2735	76	0.33
	2	2630	78	0.34
	3	2530	80	0.35
	4	2750	74	0.32
III	1	2400	59	0.30
	2	2270	59	0.29
	3	2180	62	0.30
	4	2240	60	0.29
IV	1	2380	68	0.30
	2	2200	71	0.30
	3	2150	71	0.30
	4	2520	62	0.28

# Ø 190 MM, BACKWARD CURVED

# AC CENTRIFUGAL FAN

## Overall Dimensions

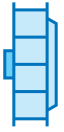

Centrifugal Fan	Weight [kg]
BL-B190A-2E-A01-01	1.41
BL-B190A-2E-A02-01	1.41



Centrifugal Fan with Plug Fan Casing	Weight [kg]
GL-B190A-2E-A01-01	2.06
GL-B190A-2E-A02-01	2.06

### BL-B190A-2E-A01-01, BL-B190A-2E-A02-01

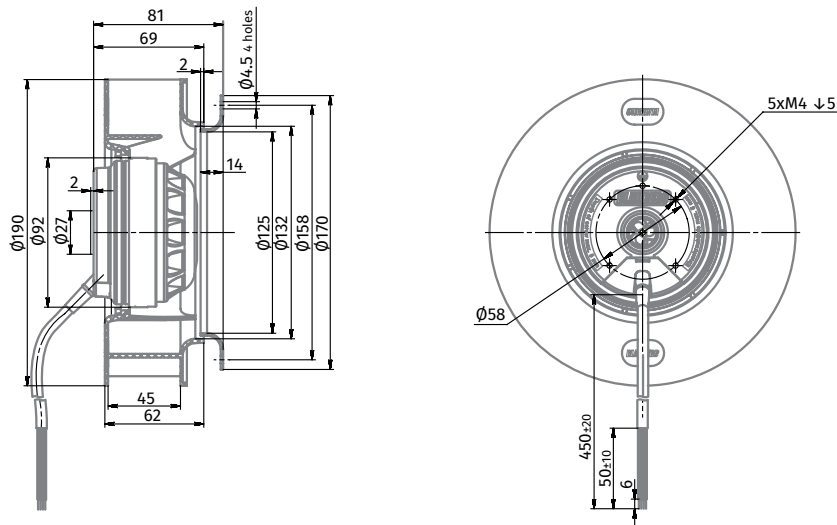

### GL-B190A-2E-A01-01, GL-B190A-2E-A02-01

