

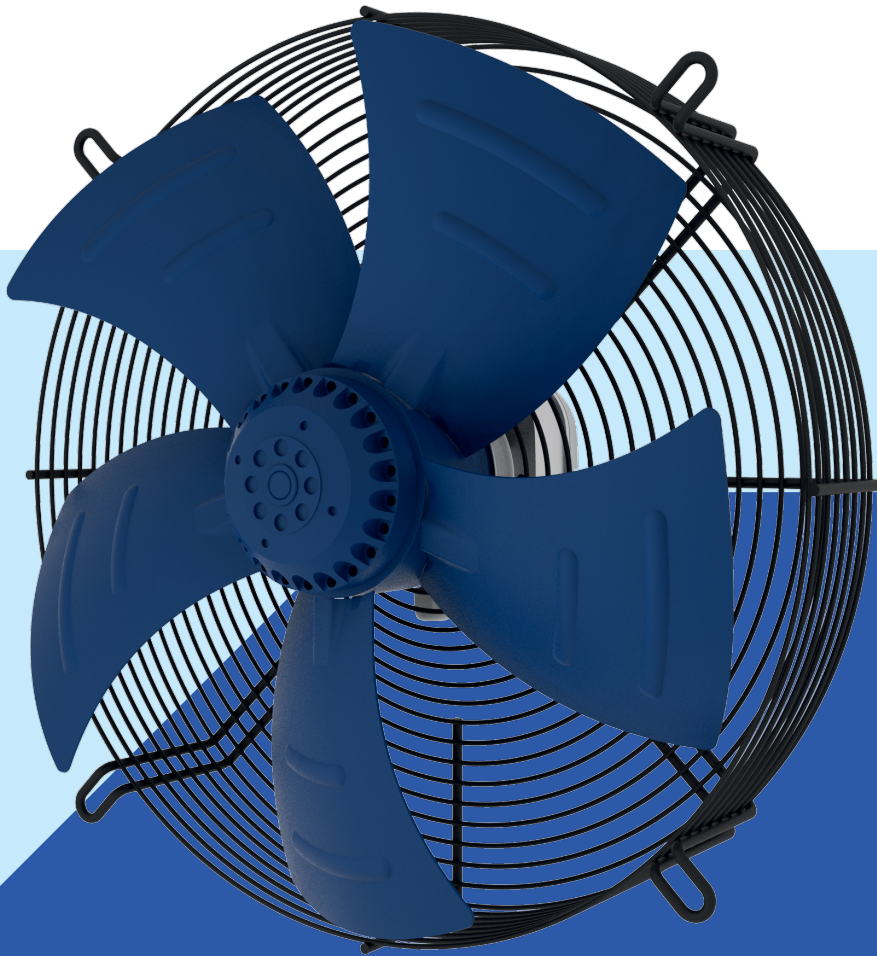

**BLAUBERG**  
Motoren

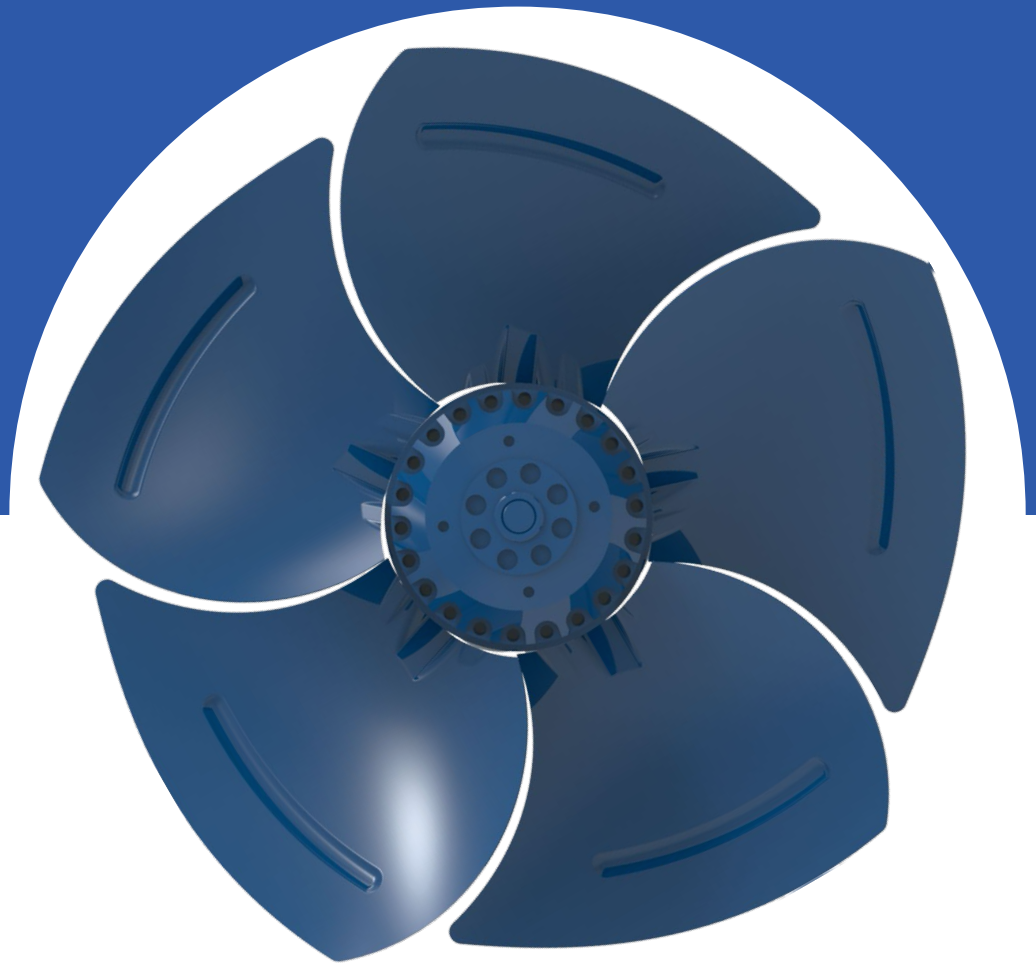

**AXIAL FANS**



## CONTENTS

About Blauberg Group	2
Fan Motors	4
Designation key	6
AC Axial Fans	8
Electrical Connection Diagram	25



**Blauberg Group manufactures and sells a complete range of hi-tech energy-efficient ventilation equipment offering a balanced mix of innovative technology, contemporary design and traditional German quality.**

The group's main products include domestic fans, single-room ventilation units, heat recovery units, industrial fans and air handling units, parts and accessories for customized system configurations as well as bespoke ventilation solutions. Due to our product diversity, we do our best to meet the individual needs of our clients in various countries with the best combination of price and quality.





**Blauberg Motoren was born in Munich, Germany, like own direction of fans and motors manufacturing and integral part of Blauberg Group.**



Starting with manufacturing AC motors with external rotors for own needs, for now Blauberg Motoren produce wide range of motors and fans with EC and AC technology for clients all around the world. It includes axial fans, backward curved fans, forward curved fans, blowers.

We are proud to be presented in products of our clients – world famous manufactures of ventilation, heat, home appliance and other equipment, and be part of their success.



For now Blauberg Motoren have R&D (research and development) center in Munich (Germany), as well as main testing laboratories for products and factories in Germany (Munich), Ukraine (Kiev) and Poland.

Every day we are working with our passion and respect to technology and engineering to make our products better – more responsive to needs and expectations of our clients.

With traditional German quality, we are focused on developing and improving best one and newest technology – in our own manufacturing and in our products.

**WE ARE CLIENT-ORIENTED COMPANY  
AND TRY TO BE BEST ONE FOR OUR CLIENTS  
IN SEGMENTS WE ARE PRESENT.**

## FAN MOTORS

### THE MOTORS ARE POWERED BY DIRECT OR ALTERNATING CURRENT.

- A direct current motor is powered by a direct power supply.
- An alternating current motor is powered by an alternating power supply.

Alternating current motors are the most widely used motors because the basic electric grid in the country has alternating power supply.

### ALTERNATING CURRENT MOTORS HAVE TWO TYPES:

- **Synchronous** electric motors are alternating current motors with a rotor that rotates synchronously with a magnetic field;
- **Asynchronous** electric motors are alternating current motors with the magnetic field frequency exceeding the motor rotation speed.

## Asynchronous motors

Nowadays the asynchronous electric motors find wide application.

### Asynchronous electric motors consist of two basic components, the stator and the rotor.

The stator is a fixed motor component. On the inner side the stator has some slots for laying of three-phase cable winding that is powered by three-phase current. The rotor is a rotating part of the motor and also has slots for inserting the cable winding. The rotor and the stator are assembled of separate 0.35-0.5 mm thick electrotechnical steel pressed plates.

Separate plates are insulated from each other with a varnish layer. The air gap between the stator and the rotor is kept as low as possible: 0.3-0.35 mm for low capacity machinery and 1.0-1.5 for more powerful machinery.

Depending on the rotor design the asynchronous motors are available in short circuit modification and phased modifications. Short circuit motors are the most widely used motors because of their simple design and easy operation. The three-phase stator winding is inserted inside the slots and consists of a number of interconnected coils. Each coil consists of one or several turns which are insulated against each other and against the slot walls.

### THE ASYNCHRONOUS ELECTRIC MOTOR WITH SHORT CIRCUIT ROTOR HAS THE FOLLOWING ADVANTAGES:

- Permanent speed at various loads.
- Resistance to short-term mechanical overloads.
- Easy structure.
- Easy start-up.
- Higher  $\cos \phi$  and efficiency compared to electric motors with phased rotor.

### The design of the asynchronous electric motor with external rotor is similar to that of the standard asynchronous electric motor.

The only difference is the position of the rotor. The electric rotor motor is located inside the stator winding and the stator with turns is located in the electric motor center. This configuration provides a compact size of the ventilation unit. The electric motor shaft is carried by ball bearings fixed inside the stator and the impeller is fixed in the rotor casing. Such a design provides air cooling of the electric motor which makes it applicable for a wide temperature range. The electric motors are assembled with the impellers and are subjected to static and dynamic balancing in compliance with DIN ISO 1940. The motors have an integrated overheating protection with automatic restart.

All the motors have 100 % controllable speed range. Speed control is performed with a transformer or electronic devices. Explosionproof motors are controlled exclusively by transformers within 25% up to 100% of the rated voltage range. Speed control is performed by voltage change whereas the frequency in the grid remains the same. The electric motor speed is smoothly decreased as power voltage drops or is increased as power voltage rises. The motor can also be controlled with a frequency converter.

### ADVANTAGES OF THE ASYNCHRONOUS ELECTRIC MOTOR WITH EXTERNAL ROTOR:

- Long service life.
- Light weight and small Overall dimensions.
- Easy assembly and installation.
- Aligned impeller and electric motor.
- Regulated air capacity.
- Low energy demand during start-up.



## EC motors

The electric motor with high-efficient EC motor is a synchronous direct current motor driven by an electronic commutating unit (controller). It has no friction and wearing parts as a collector or brushes, unlike the standard motor. The function of these parts is performed with the maintenance-free electronic circuit of the EC controller.

The EC technology is the state-of-the-art method for arrangement of energy saving and high efficient ventilation.

**The energy demand of EC motors is by 50% less as compared to standard motors and efficiency reaches 90%.**

These new electric motors are featured with high performance, low noise level and controllable total speed range. The electronic EC-controller enables some other smart functions, e.g. fan control according to measured temperature, pressure and other parameters.

A unique software ensures high control accuracy for fans integrated into a single network. Parameters of a single fan integrated into a common network may be centrally corrected to match the ventilation system parameters. All the system parameters are displayed online on a computer. This enables programming individual operation modes of each fan in the system. This technology enables also programming custommade settings to meet individual customer requirements.



### ADVANTAGES OF EC MOTORS:

- Efficient performance at any rotation speed of the fan, including very low speed.
- Low heat emission.
- Small Overall dimensions of the unit due to external rotor design.
- Maximum fan rotation speed does not depend on frequency in the grid.
- The fan is suitable for connection both to 50 Hz and 60 Hz power mains.
- High efficiency at low rotation speed.
- Energy demand is by 1/3 less as compared to standard motors.
- Data interchange between PC and fan for parameter setting and control.
- Integration of all fans into a unified system and their centralized control.

## DESIGNATION KEY

### AC fans

#### BL-A200A-2E-A01-S3

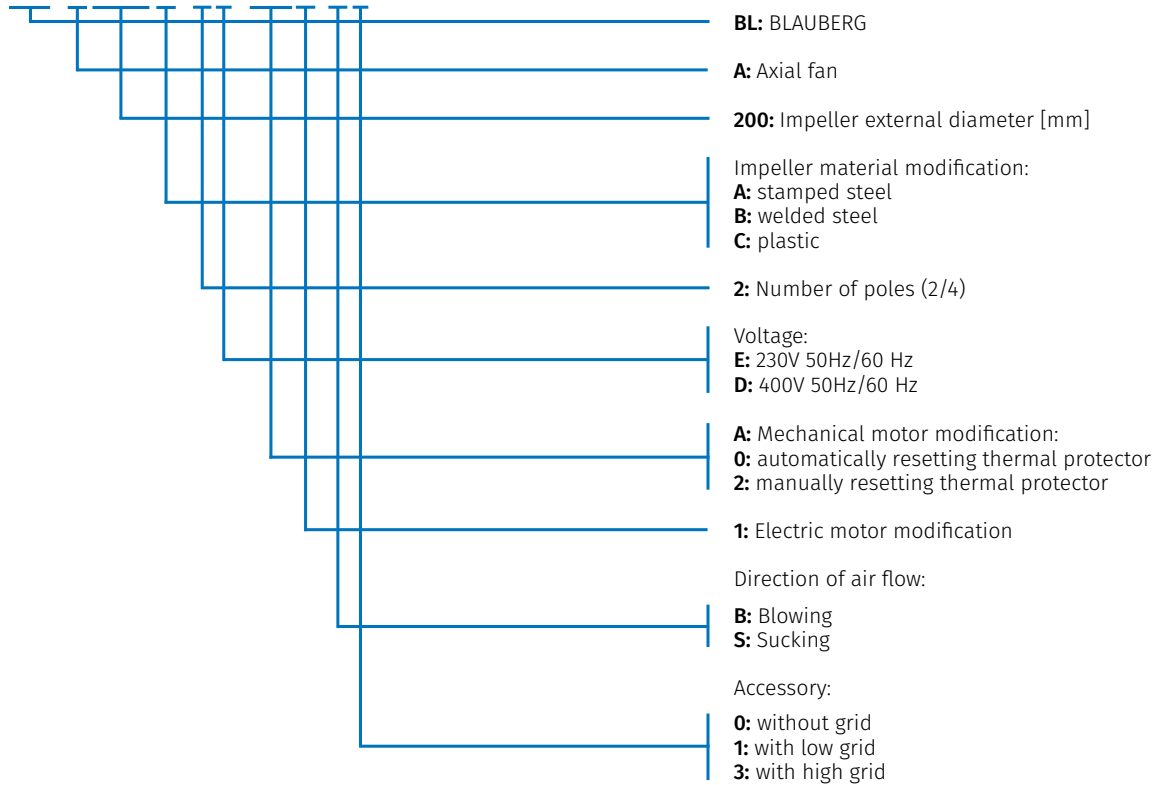

### Axis-Q/Axis-F

#### AXIS-Q 200 2E

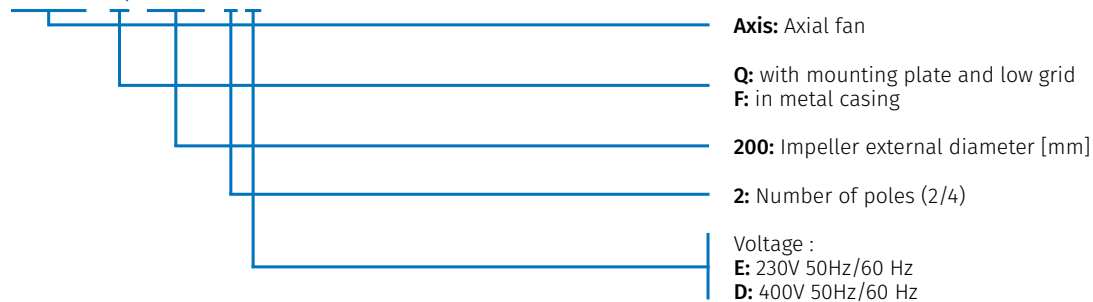



# AC AXIAL FANS

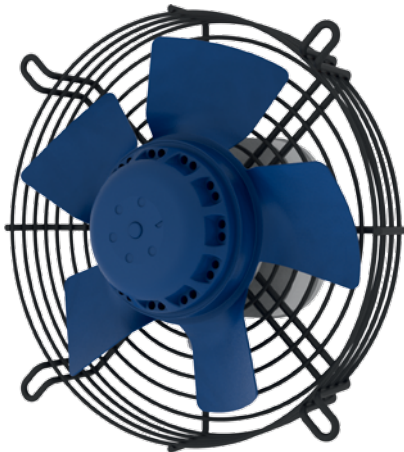

### Features

- **Impeller material:** alkyd coated steel, stamped
- **Direction of rotation:** clockwise for blowing "B" and counter-clockwise for sucking "S", seen on rotor
- **Type of protection:** IP44
- **Insulation class:** B
- **Mode of operation:** continuous operation (S1)
- **Bearing:** ball bearings
- **Motor protection:** self-resetting TOP wired internally



### Technical data

Model	Perform. curve	Nominal voltage [VAC]	Frequency [Hz]	Speed [RPM]	Power input max [W]	Current max [A]	Sound pres. level [dB(A)]	Perm. amb. temp. [°C]	Capacitor [µF/VDB]	Electrical connection
BL-A200A-2E-A01-B* BL-A200A-2E-A01-S*	I	230	50	2540	67	0.29	60	-25 ... +50	1.5/450	A
Axis-Q 200 2E Axis-Q 200 2E	II	230	60	2650	84	0.36	62	-25 ... +50	1.5/450	A

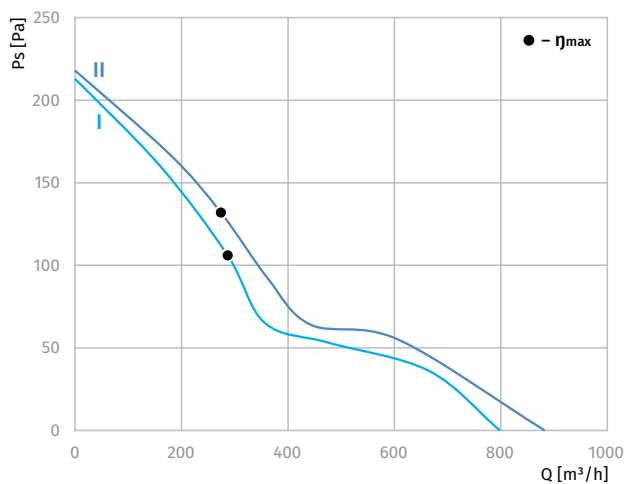

# Ø 200 MM, STAMPED

# AC AXIAL FAN

## Overall Dimensions



Axial Fan *no grid	Weight [kg]
BL-A200A-2E-A01-B0	1.56
BL-A200A-2E-A01-S0	1.56

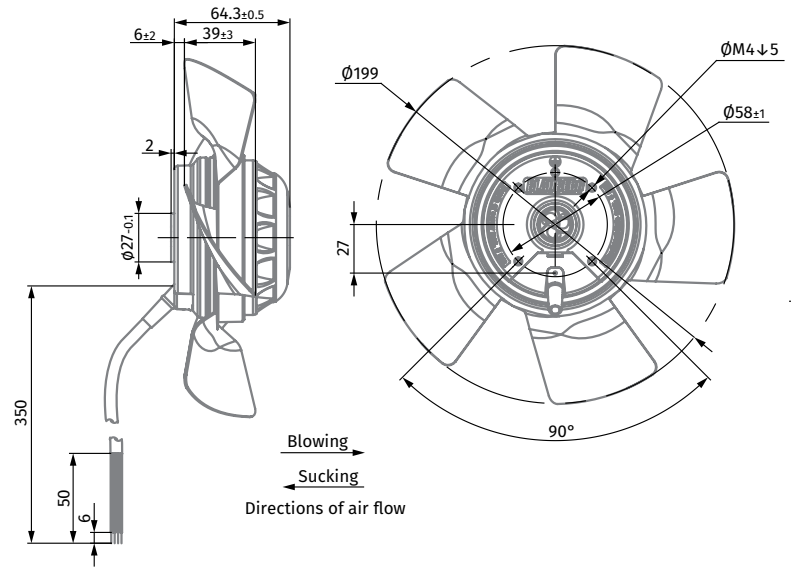

Axial Fan *with low grid	Weight [kg]
BL-A200A-2E-A01-B1	1.68
BL-A200A-2E-A01-S1	1.68

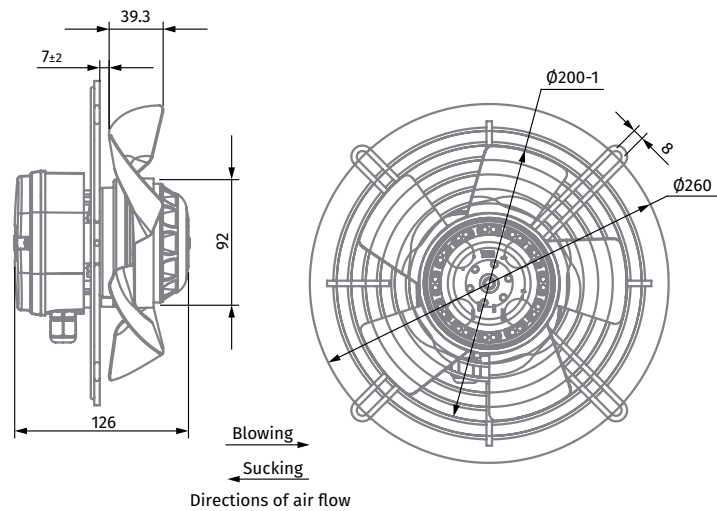

Axial Fan *with high grid	Weight [kg]
BL-A200A-2E-A01-B3	1.9
BL-A200A-2E-A01-S3	1.9

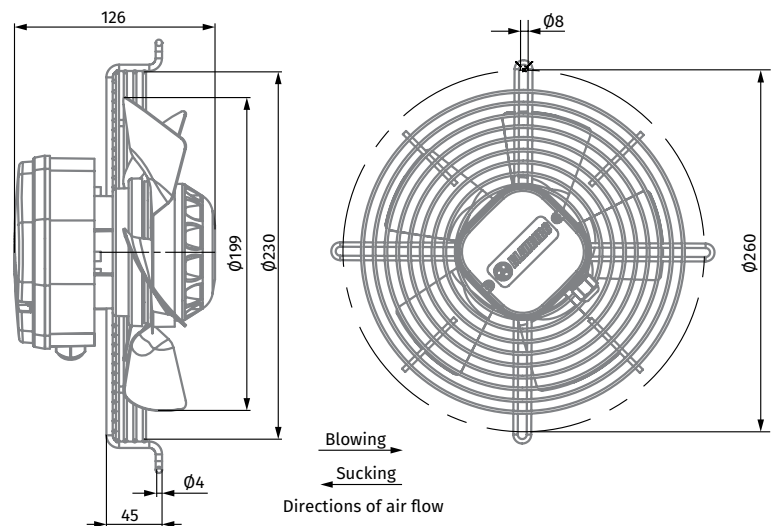

Ø 200 mm, STAMPED

AC AXIAL FAN



Axial Fan *with mounting plate and low grid	Weight [kg]
Axis-Q 200 2E	3.0

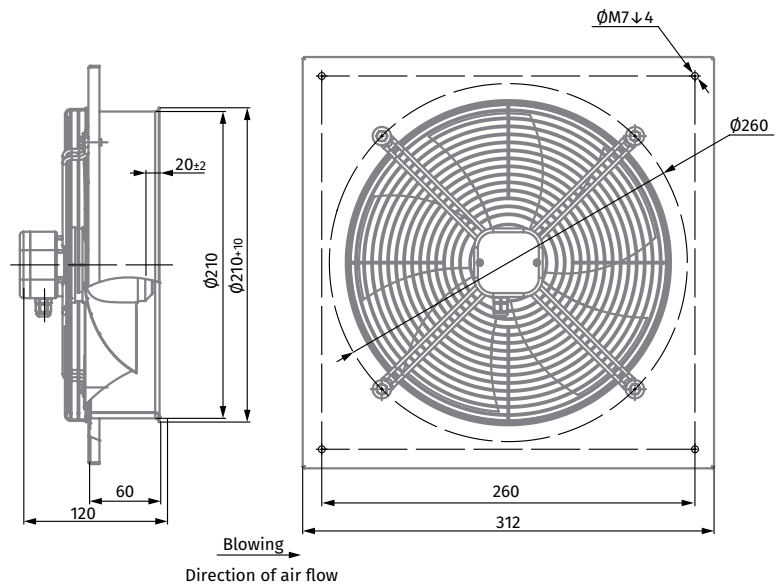

Axial Fan *in metal casing	Weight [kg]
Axis-F 200 2E	3.0

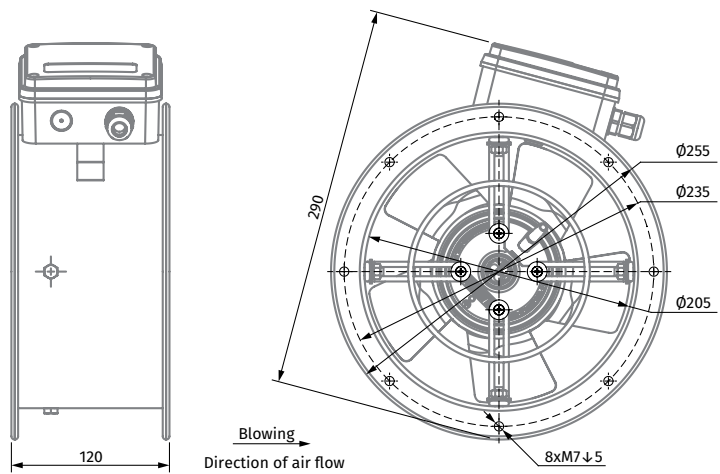

# Ø 250 MM, STAMPED

# AC AXIAL FAN

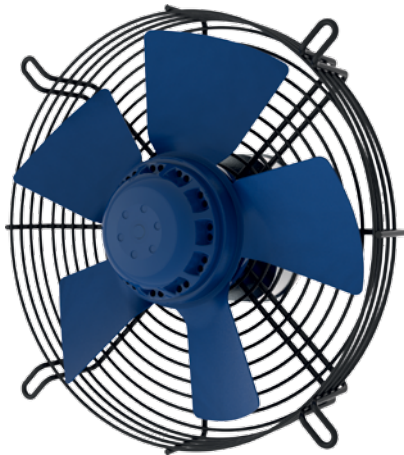

### Features

- **Impeller material:** alkyd coated steel, stamped
- **Direction of rotation:** clockwise for blowing "B" and counter-clockwise for sucking "S", seen on rotor
- **Type of protection:** IP44
- **Insulation class:** B
- **Mode of operation:** continuous operation (S1)
- **Bearing:** ball bearings
- **Motor protection:** self-resetting TOP wired internally



### Technical data

Model	Perform. curve	Nominal voltage [VAC]	Frequency [Hz]	Speed [RPM]	Power input max [W]	Current max [A]	Sound pres. level [dB(A)]	Perm. amb. temp. [°C]	Capacitor [µF/VDB]	Electrical connection
BL-A250A-2E-B01-B* BL-A250A-2E-B01-S*	I	230	50	2480	117	0.52	60	-25 ... +50	2.0/450	A
Axis-Q 250 2E Axis-F 250 2E	II	230	60	2560	140	0.61	62	-25 ... +50	2.0/450	A
BL-A250A-4E-B01-B* BL-A250A-4E-B01-S*	III	230	50	1380	53	0.23	54	-25 ... +50	2.0/450	A
Axis-F 250 4E Axis-Q 250 4E	IV	230	60	1550	67	0.30	58	-25 ... +50	2.0/450	A

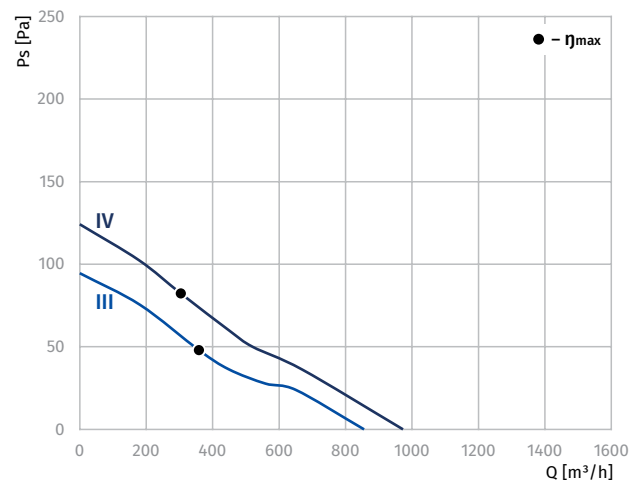
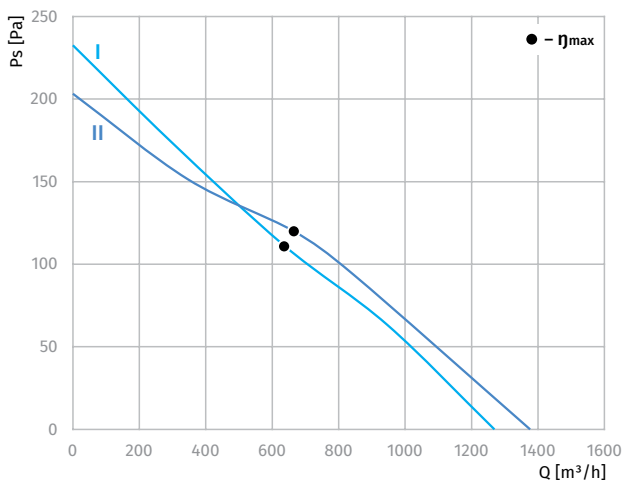

# Ø 250 MM, STAMPED

# AC AXIAL FAN

## Overall Dimensions



Axial Fan *no grid	Weight [kg]
BL-A250A-2E-B01-B0	2.4
BL-A250A-2E-B01-S0	2.4
BL-A250A-4E-B01-B0	1.9
BL-A250A-4E-B01-S0	1.9

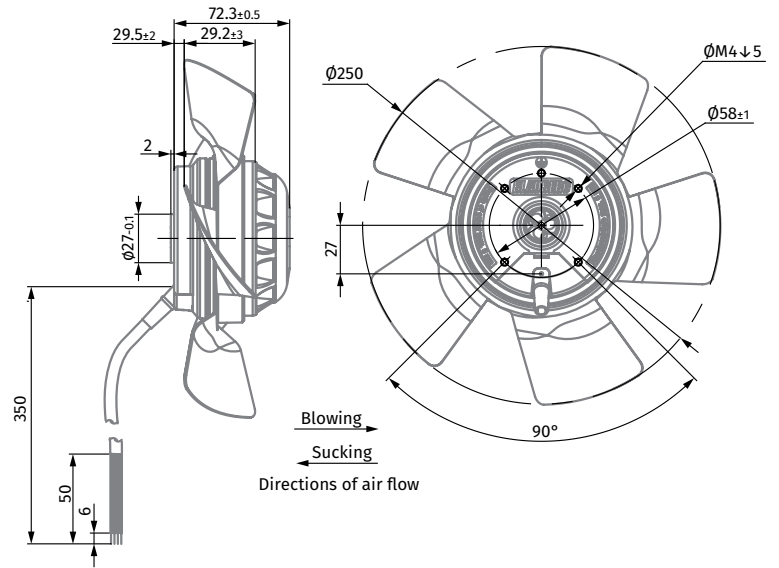

Axial Fan *with low grid	Weight [kg]
BL-A250A-2E-B01-B1	2.7
BL-A250A-2E-B01-S1	2.7
BL-A250A-4E-B01-B1	2.2
BL-A250A-4E-B01-S1	2.2

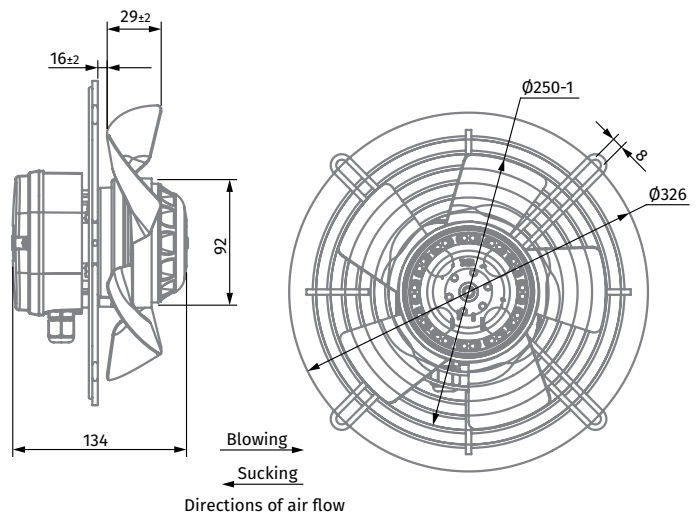

Axial Fan *with high grid	Weight [kg]
BL-A250A-2E-B01-B3	3.0
BL-A250A-2E-B01-S3	3.0
BL-A250A-4E-B01-B3	2.5
BL-A250A-4E-B01-S3	2.5

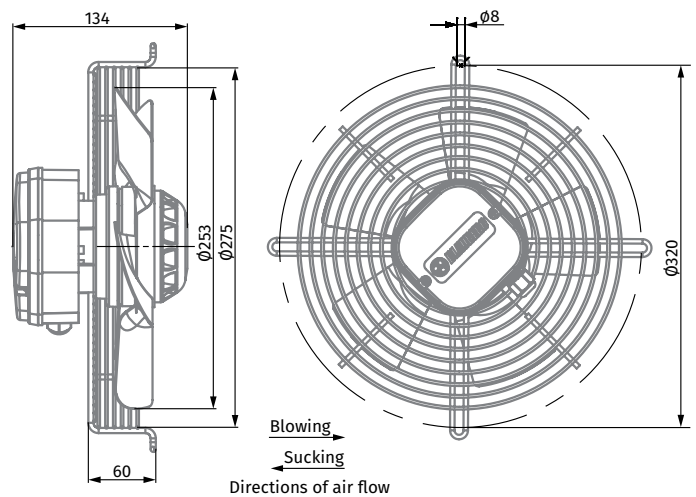

# Ø 250 MM, STAMPED

# AC AXIAL FAN



Axial Fan *with mounting plate and low grid	Weight [kg]
Axis-Q 250 2E	4.0
Axis-Q 250 4E	3.5

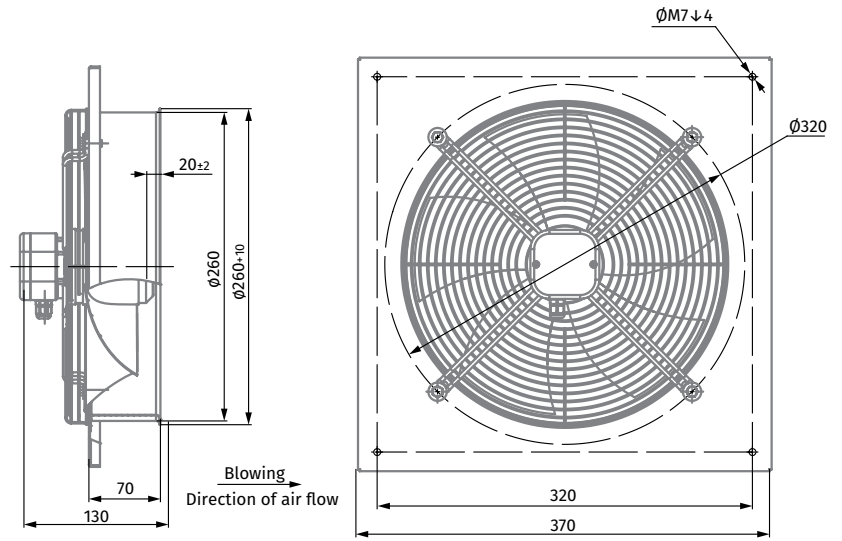

Axial Fan *in metal casing	Weight [kg]
Axis-F 250 2E	4.0
Axis-F 250 4E	3.5

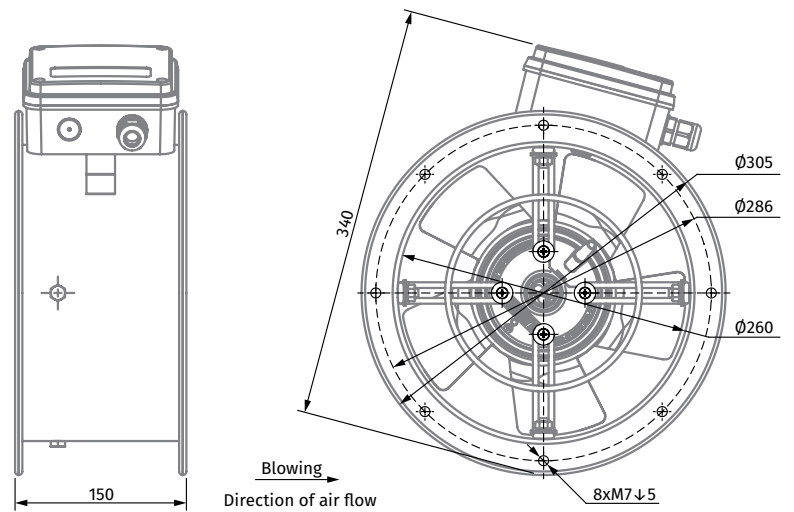

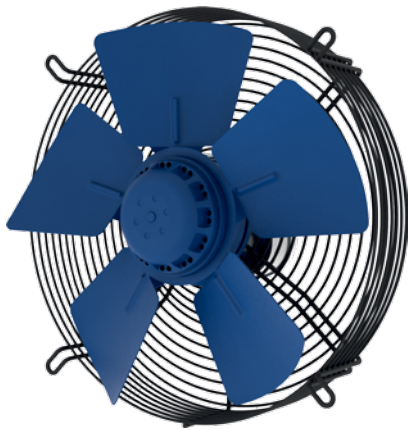

### Features

- **Impeller material:** alkyd coated steel, stamped
- **Direction of rotation:** clockwise for blowing "B" and counter-clockwise for sucking "S", seen on rotor
- **Type of protection:** IP44
- **Insulation class:** B
- **Mode of operation:** continuous operation (S1)
- **Bearing:** ball bearings
- **Motor protection:** self-resetting TOP wired internally



### Technical data

Model	Perform. curve	Nominal voltage [VAC]	Frequency [Hz]	Speed [RPM]	Power input max [W]	Current max [A]	Sound pres. level [dB(A)]	Perm. amb. temp. [°C]	Capacitor [µF/VDB]	Electrical connection
BL-A300A-4E-C01-B* BL-A300A-4E-C01-S*	I	230	50	1290	93	0.41	59	-25 ... +50	3.0/450	A
Axis-Q 300 4E Axis-F 300 4E	II	230	60	1380	116	0.50	63	-25 ... +50	3.0/450	A

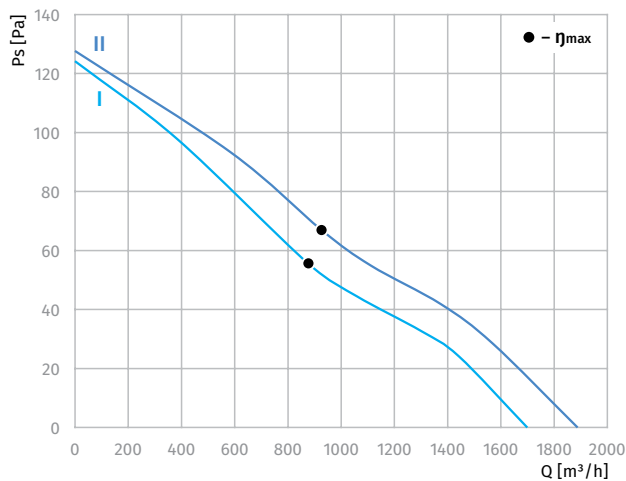



# Ø 300 MM, STAMPED

# AC AXIAL FAN

## Overall Dimensions



Axial Fan *no grid	Weight [kg]
BL-A300A-4E-C01-B0	2.4
BL-A300A-4E-C01-S0	2.4

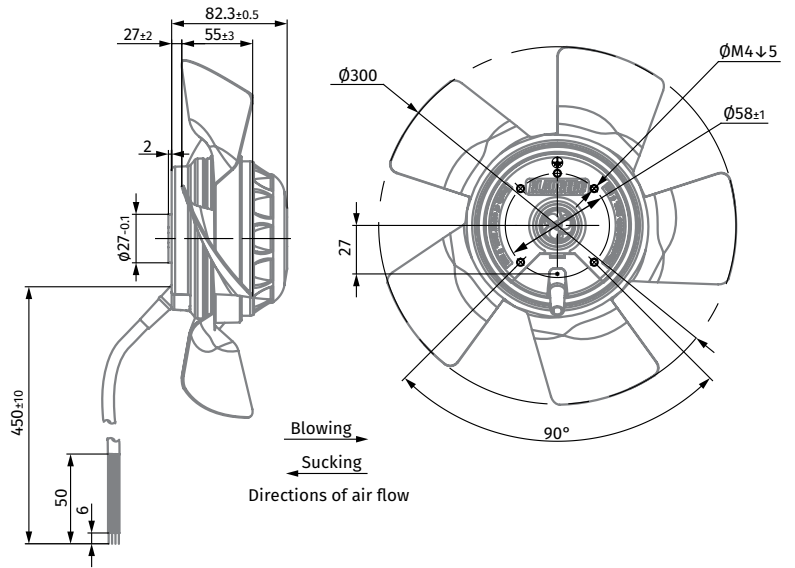

Axial Fan *with low grid	Weight [kg]
BL-A300A-4E-C01-B1	2.8
BL-A300A-4E-C01-S1	2.8

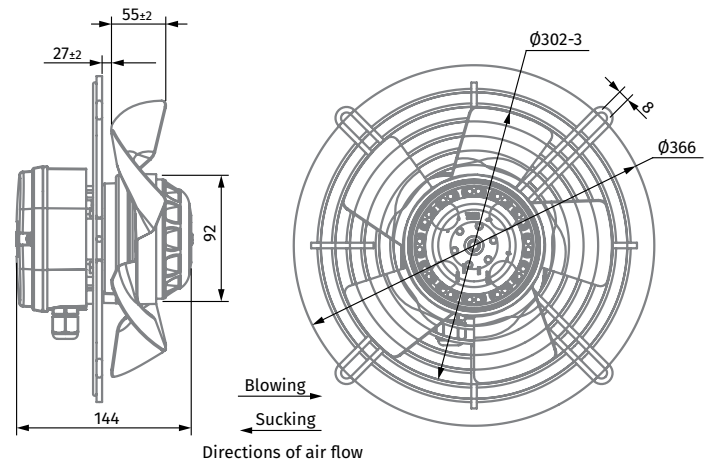

Axial Fan *with high grid	Weight [kg]
BL-A300A-4E-C01-B3	3.2
BL-A300A-4E-C01-S3	3.2

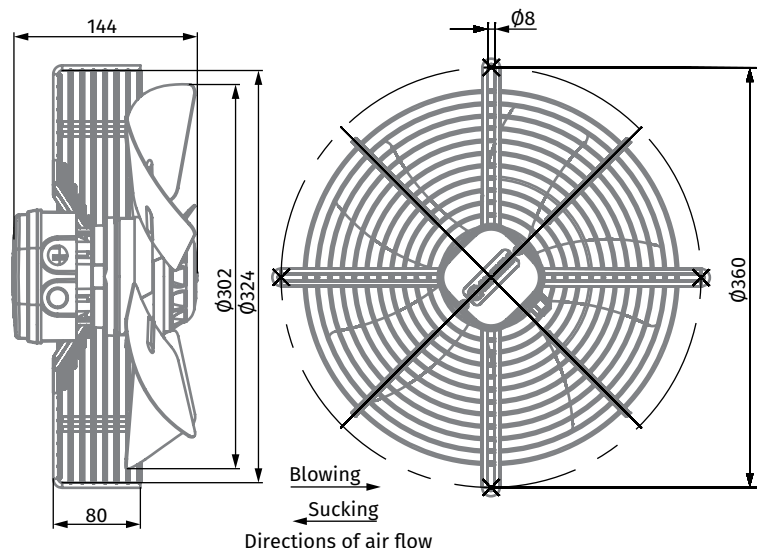

Ø 300 MM, STAMPED

AC AXIAL FAN



Axial Fan *with mounting plate and low grid	Weight [kg]
Axis-Q 300 4E	5.0

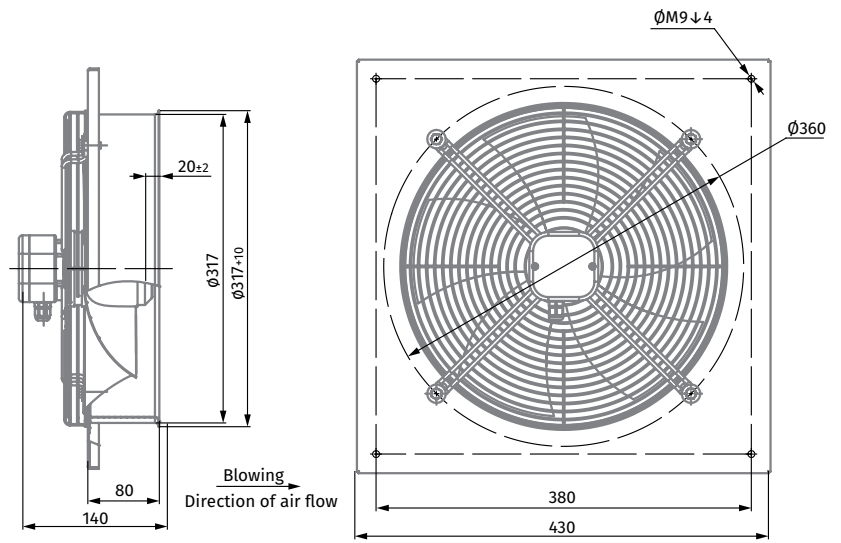

Axial Fan *in metal casing	Weight [kg]
Axis-F 300 4E	6.2

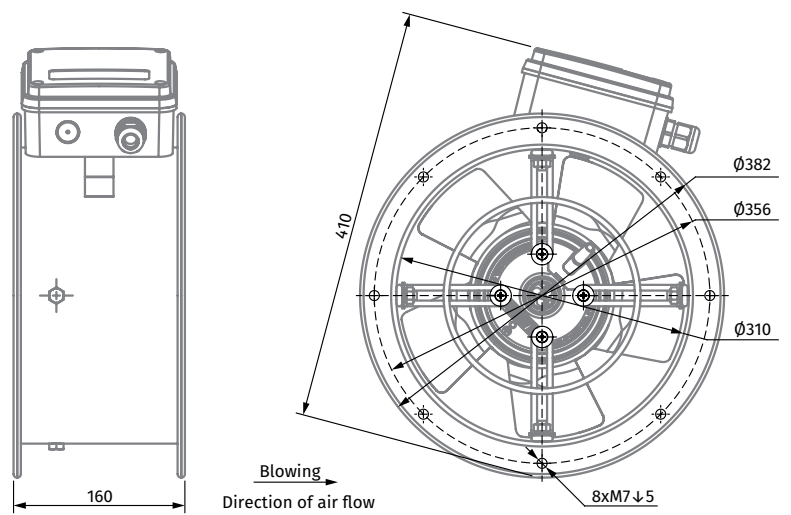

Ø 350 MM, WELDED

AC AXIAL FAN

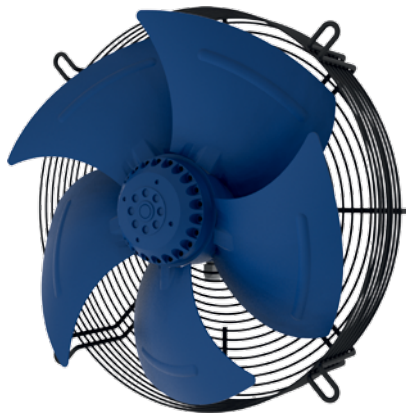

Features

- **Impeller material:** alkyd coated steel, welded
- **Direction of rotation:** clockwise for blowing "B" and counter-clockwise for sucking "S", seen on rotor
- **Type of protection:** IP54
- **Insulation class:** F
- **Mode of operation:** continuous operation (S1)
- **Bearing:** ball bearings
- **Motor protection:** self-resetting TOP wired internally



Technical data

Model	Perform. curve	Nominal voltage [VAC]	Frequency [Hz]	Speed [RPM]	Power input max [W]	Current max [A]	Sound pres. level [dB(A)]	Perm. amb. temp. [°C]	Capacitor [µF/VDB]	Electrical connection
BL-A350B-4E-L01-B*	I	230	50	1330	218	0.97	63	-25 ... +50	4.0/450	A
BL-A350B-4E-L01-S*										
Axis-Q 350 4E	II	230	60	1570	248	1.10	67	-25 ... +50	4.0/450	A

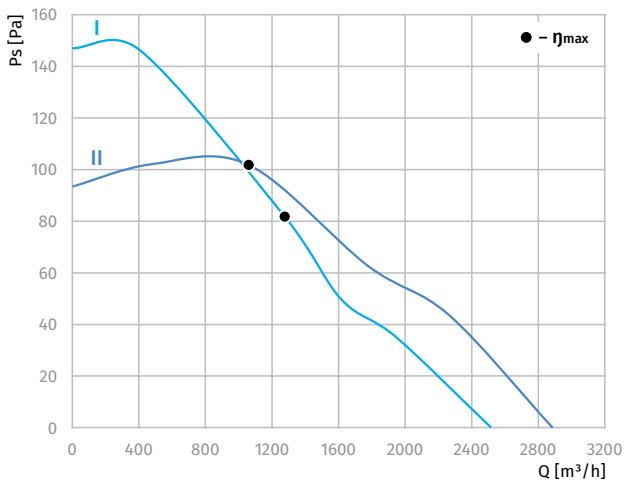

Ø 350 mm, WELDED

AC AXIAL FAN

Overall Dimensions



Axial Fan *no grid	Weight [kg]
BL-A350B-4E-L01-B0	3.7
BL-A350B-4E-L01-S0	3.7

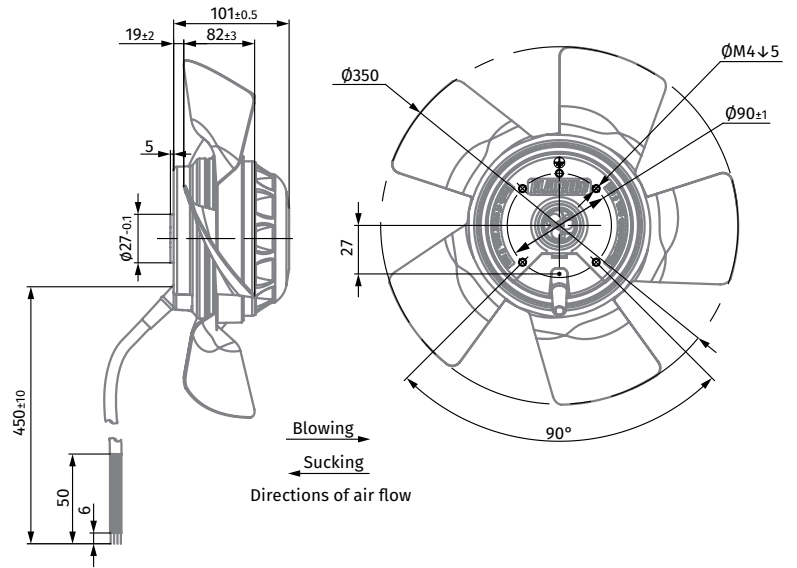

Axial Fan *with low grid	Weight [kg]
BL-A350B-4E-L01-B1	4.2
BL-A350B-4E-L01-S1	4.2

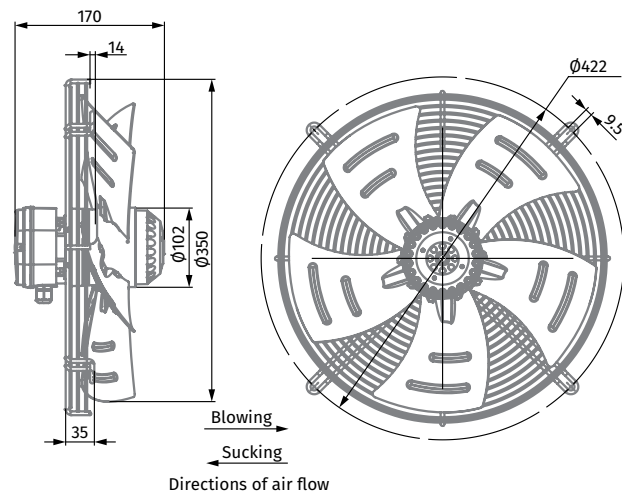

Axial Fan *with high grid	Weight [kg]
BL-A350B-4E-L01-B3	4.7
BL-A350B-4E-L01-S3	4.7

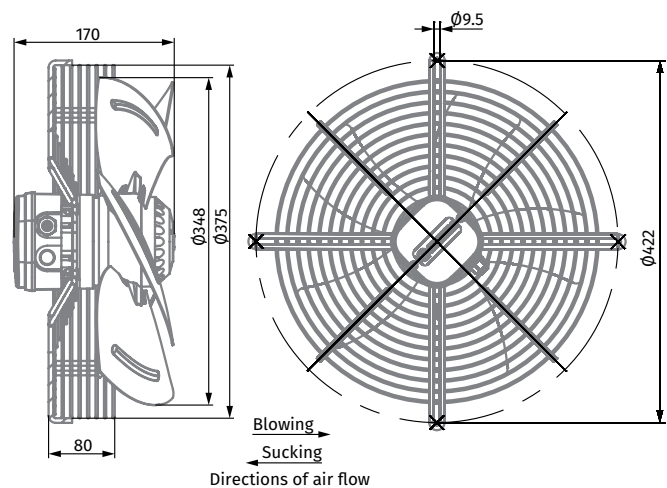

Ø 350 mm, WELDED

AC AXIAL FAN



Axial Fan *with mounting plate and low grid	Weight [kg]
Axis-Q 350 4E	7.8

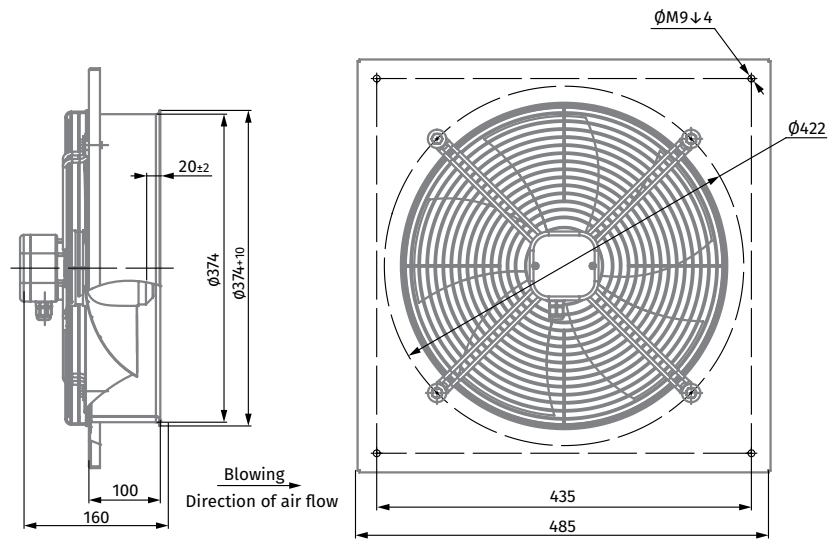

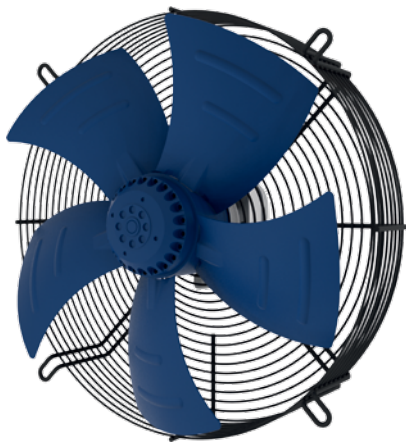

**Features**

- **Impeller material:** alkyd coated steel, welded
- **Direction of rotation:** clockwise for blowing "B" and counter-clockwise for sucking "S", seen on rotor
- **Type of protection:** IP54
- **Insulation class:** F
- **Mode of operation:** continuous operation (S1)
- **Bearing:** ball bearings
- **Motor protection:** self-resetting TOP wired internally



**Technical data**

Model	Perform. curve	Nominal voltage [VAC]	Frequency [Hz]	Speed [RPM]	Power input max [W]	Current max [A]	Sound pres. level [dB(A)]	Perm. amb. temp. [°C]	Capacitor [µF/VDB]	Electrical connection
BL-A400B-4E-M01-B*	I	230	50	1400	290	1.27	63	-25 ... +50	6.0/450	A
BL-A400B-4E-M01-S*										
Axis-Q 400 4E	II	230	60	1600	331	1.43	67	-25 ... +50	6.0/450	A

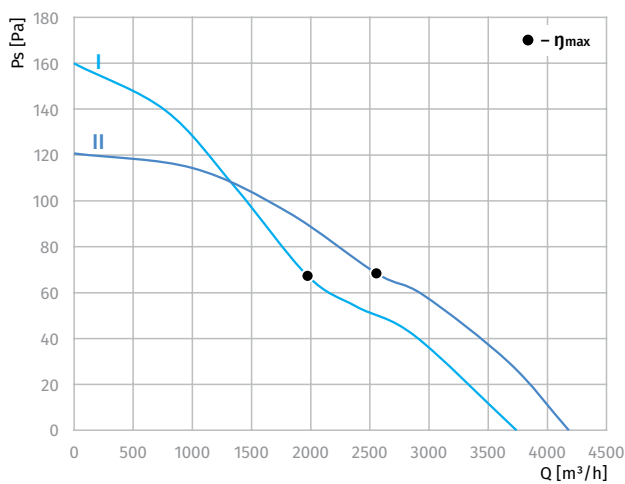

# Ø 400 mm, WELDED

# AC AXIAL FAN

## Overall Dimensions



Axial Fan *no grid	Weight [kg]
BL-A400B-4E-M01-B0	4.4
BL-A400B-4E-M01-S0	4.4

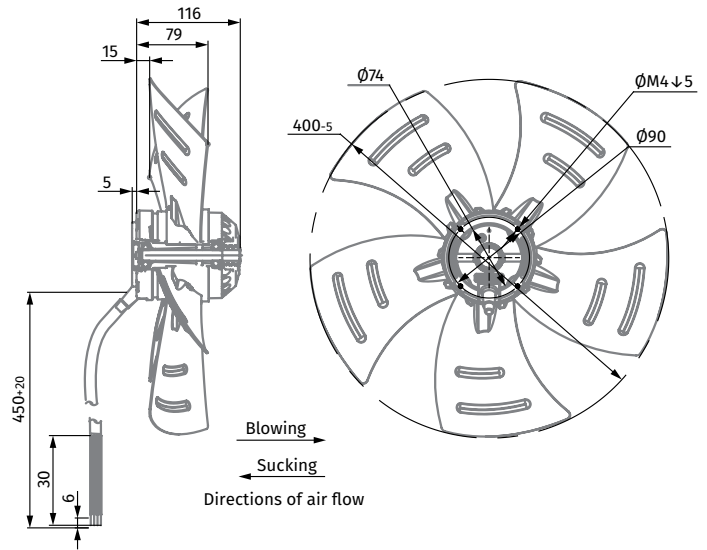

Axial Fan *with low grid	Weight [kg]
BL-A400B-4E-M01-B1	5.3
BL-A400B-4E-M01-S1	5.3

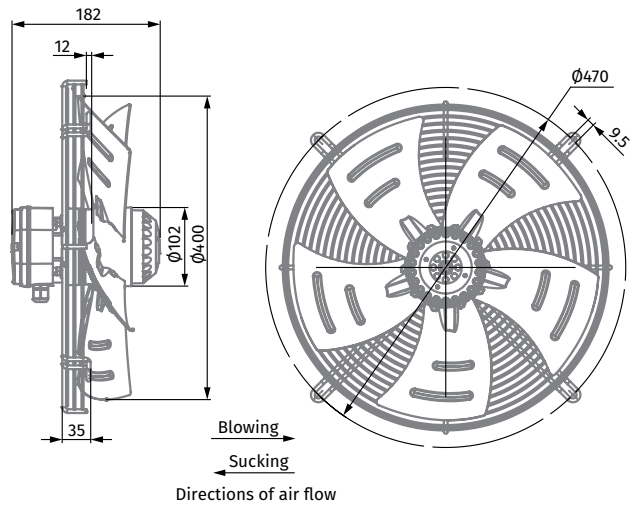

Axial Fan *with high grid	Weight [kg]
BL-A400B-4E-M01-B3	5.7
BL-A400B-4E-M01-S3	5.7

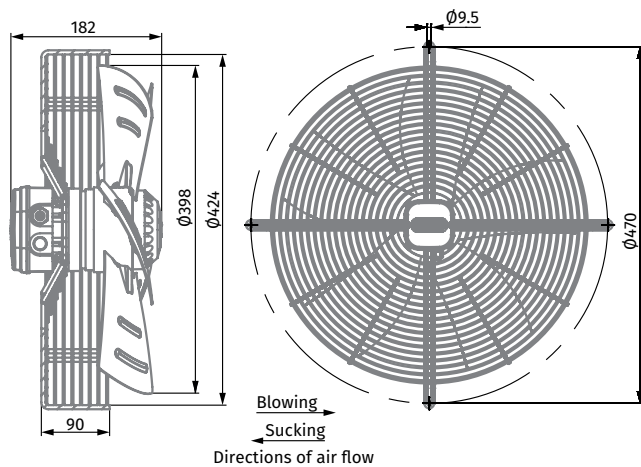



Axial Fan \*with mounting plate and low grid

Weight [kg]

Axis-Q 400 4E

8.8

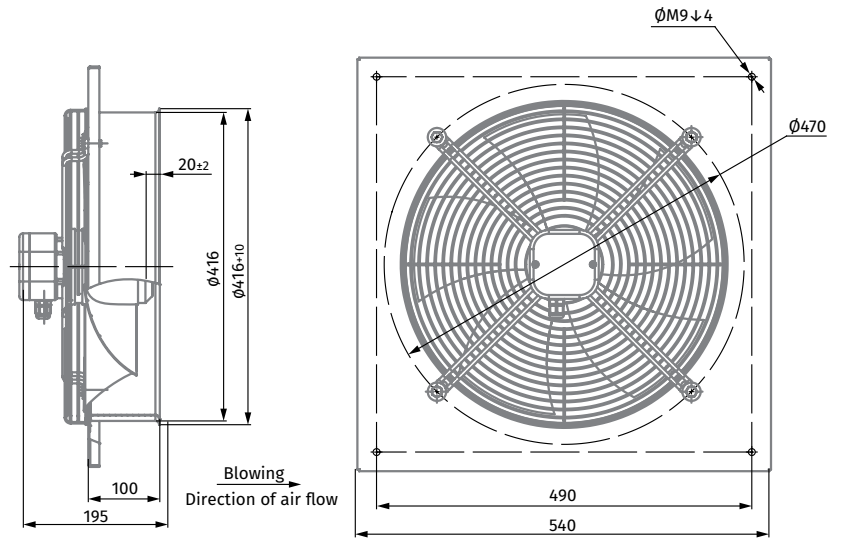



Ø 450 mm, WELDED

AC AXIAL FAN

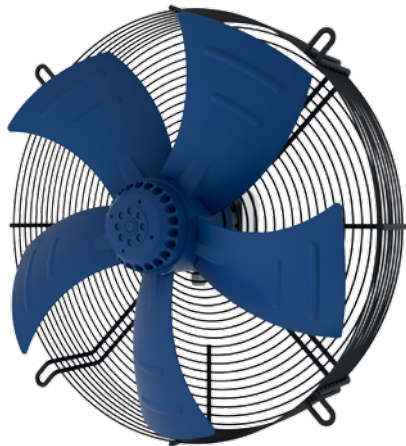

Features

- **Impeller material:** alkyd coated steel, welded
- **Direction of rotation:** clockwise for blowing "B" and counter-clockwise for sucking "S", seen on rotor
- **Type of protection:** IP54
- **Insulation class:** F
- **Mode of operation:** continuous operation (S1)
- **Bearing:** ball bearings
- **Motor protection:** self-resetting TOP wired internally



Technical data

Model	Perform. curve	Nominal voltage [VAC]	Frequency [Hz]	Speed [RPM]	Power input max [W]	Current max [A]	Sound pres. level [dB(A)]	Perm. amb. temp. [°C]	Capacitor [µF/VDB]	Electrical connection
BL-A450B-4E-N01-B*	I	230	50	1310	317	1.40	64	-25 ... +50	8.0/450	A
BL-A450B-4E-N01-S*	II	230	60	1390	425	1.85	68	-25 ... +50	8.0/450	A

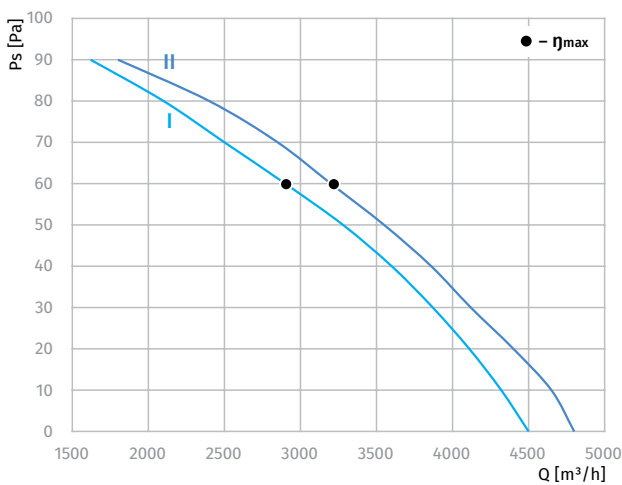

Ø 450 mm, WELDED

AC AXIAL FAN

Overall Dimensions



Axial Fan *no grid	Weight [kg]
BL-A450B-4E-N01-B0	6.5
BL-A450B-4E-N01-S0	6.5

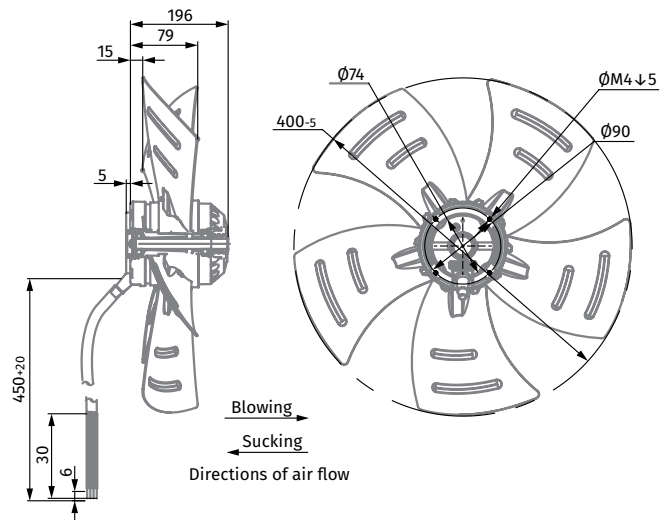

Axial Fan *with low grid	Weight [kg]
BL-A450B-4E-N01-B1	7.7
BL-A450B-4E-N01-S1	7.7

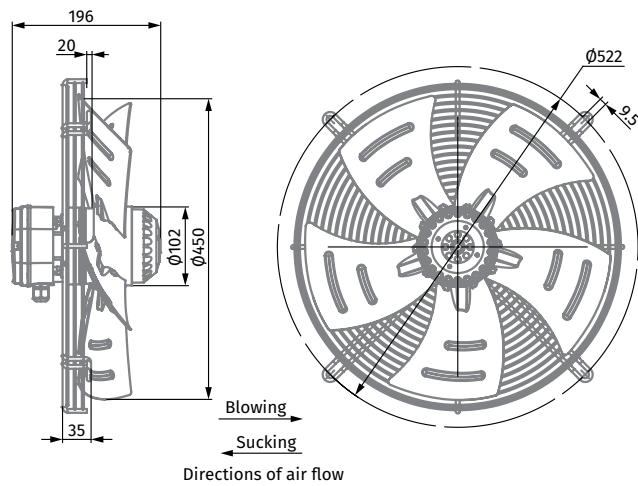

Axial Fan *with high grid	Weight [kg]
BL-A450B-4E-N01-B3	8
BL-A450B-4E-N01-S3	8

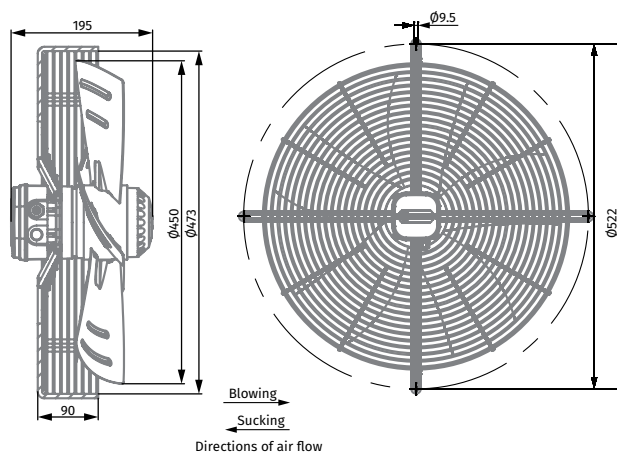

## ELECTRICAL CONNECTION DIAGRAM

### Type "A"

- U1 Blue
- U2 Black
- Z1 Brown
- PE Green/Yellow

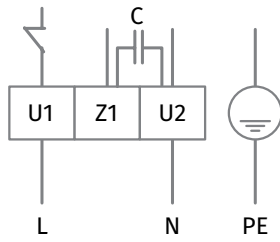









HQ: Blauberg Motoren™ by  
Blauberg Ventilatoren GmbH  
Stäblistraße 6. 81477 München,  
VAT ID: DE 287350231  
NA: Blauberg NA LLC  
174 N. 36th Street. Lafayette, IN 47905  
PL Tel. +4 822 256 53 44  
US Tel. +1 765-780-7139

[sales@blauberg-motoren.com](mailto:sales@blauberg-motoren.com)  
[info@blauberg-na.com](mailto:info@blauberg-na.com)

[blauberg-motoren.com](http://blauberg-motoren.com)

Technical changes reserved.  
Illustrations and texts are non-binding