

Ø 190 mm, BACKWARD CURVED

EC CENTRIFUGAL FAN



Features

- **Materials:** Impeller – PA6+GF30
Inlet ring – PA6+GF30
Housing – sheet steel, painted grey
- **Direction of rotation:** clockwise, seen on rotor
- **Type of protection:** IP55
- **Insulation class:** B
- **Mode of operation:** S1
- **Bearing:** ball bearings
- **Motor protection:** self-resetting TOP wired internally



Technical data

Model	Perform. curve	Nominal voltage [VAC]	Frequency [Hz]	Speed [RPM]	Power input max [W]	Current max [A]	Sound pres. level [dB(A)]	Perm. amb. temp. [°C]	Electrical connection	Inlet ring
GL-B190B-EC-00	I	230	50/60	3300	87	0.7	72	-25 ... +60	Type "E"/p. 39	p.38
GL-B190B-EC-01	II	230	50/60	3000	64	0.5	71	-25 ... +60	Type "E"/p. 39	p.38
GL-B190B-EC-03	III	230	50/60	4100	170	1.3	72	-25 ... +60	Type "E"/p. 39	p.38

PERFORMANCE CURVES

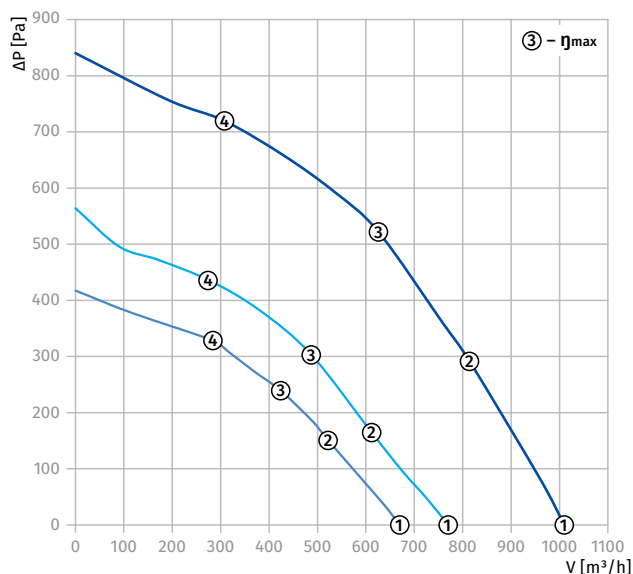

Curve	Point	n [RPM]	Pi [W]	I [A]
I	1	3340	82	0.67
	2	3310	85	0.69
	3	3300	87	0.7
	4	3280	86	0.7
II	1	2990	59	0.47
	2	2960	62	0.48
	3	3000	64	0.5
	4	2965	62	0.49
III	1	4210	151	1.12
	2	4170	167	1.23
	3	4100	170	1.3
	4	4220	151	1.13

Ø 190 MM, BACKWARD CURVED

EC CENTRIFUGAL FAN

Overall Dimensions



Centrifugal Fan	Weight [kg]
BL-B190B-EC-00	1.1
BL-B190B-EC-01	1.1
BL-B190B-EC-03	1.65



Centrifugal Fan with Plug Fan Casing	Weight [kg]
GL-B190B-EC-00	1.75
GL-B190B-EC-01	1.75
GL-B190B-EC-03	2.3

BL-B190B-EC-00, BL-B190B-EC-01

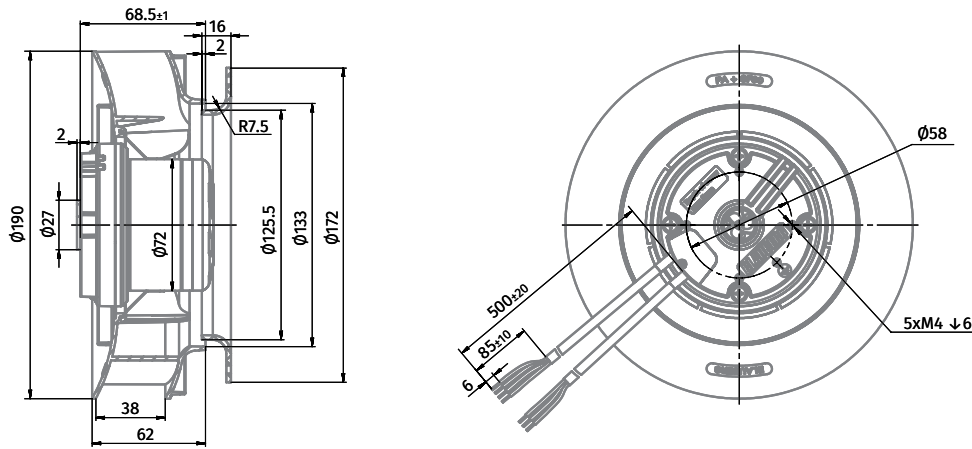

GL-B190B-EC-00, GL-B190B-EC-01

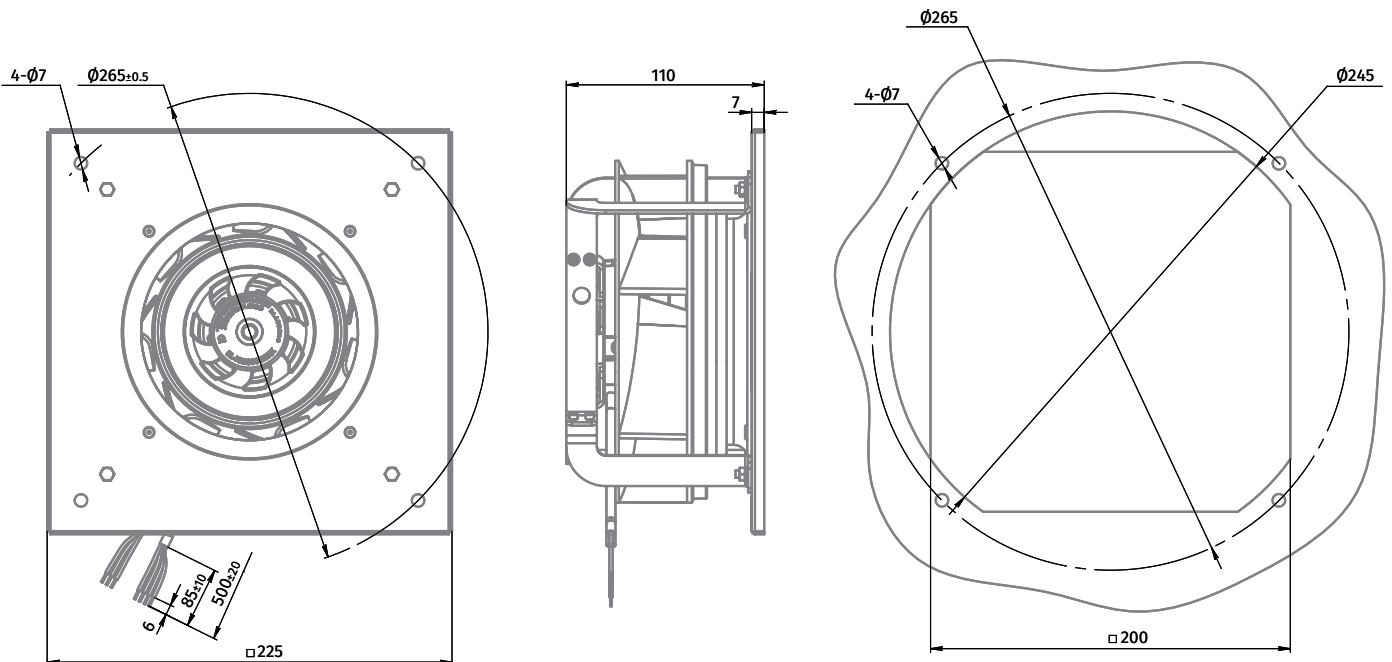

Ø 133

Ø 175

Ø 190

Ø 220

Ø 225

Ø 250

Ø 190

Ø 220

Ø 225

Ø 250

Ø 190 mm, BACKWARD CURVED

EC CENTRIFUGAL FAN

BL-B190B-EC-03

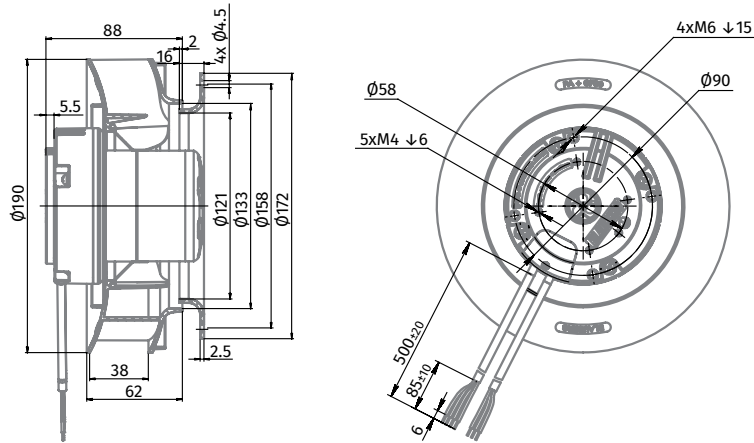

GL-B190B-EC-03

