

Ø 250 MM, BACKWARD CURVED

EC CENTRIFUGAL FAN

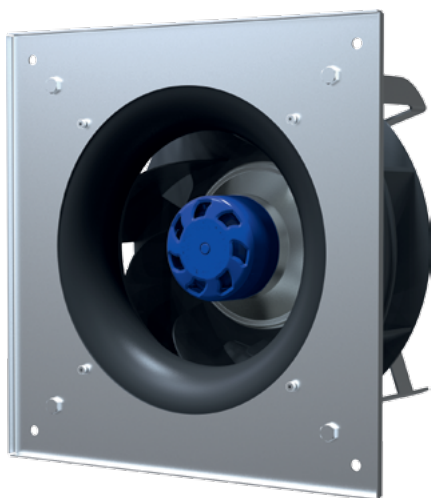

Features

- **Materials:** Impeller – PA6+GF30
Inlet ring – PA6+GF30
Housing – sheet steel, painted grey
- **Direction of rotation:** clockwise, seen on rotor
- **Type of protection:** IP55
- **Insulation class:** B
- **Mode of operation:** S1
- **Bearing:** ball bearings
- **Motor protection:** self-resetting TOP wired internally



Technical data

Model	Perform. curve	Nominal voltage [VAC]	Frequency [Hz]	Speed [RPM]	Power input max [W]	Current max [A]	Sound pres. level [dB(A)]	Perm. amb. temp. [°C]	Electrical connection	Inlet ring
*C-B250B-EC-00	I	120	60	1716	85	1.1	72	-25 ... +60	Type "E"/p. 37	p.36
*C-B250B-EC-01	II	120	60	2400	173	2.2	73	-25 ... +60	Type "E"/p. 37	p.36

PERFORMANCE CURVES

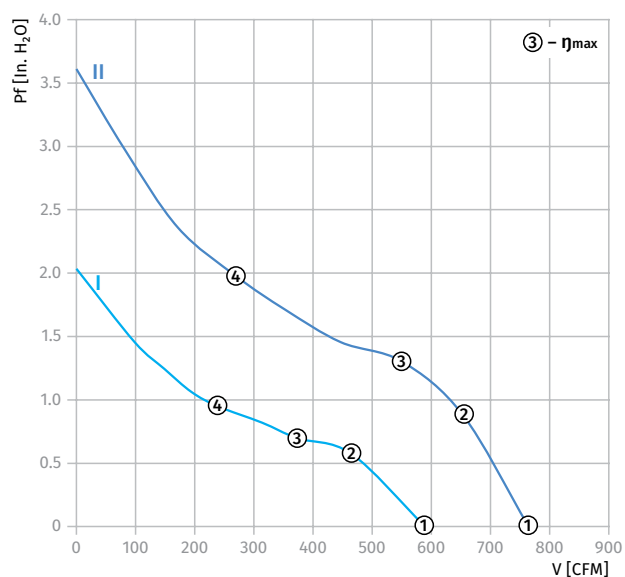

Curve	Point	n [RPM]	Pi [W]	I [A]
I	1	1956	81.9	1.115
	2	1752	75.8	1.046
	3	1716	75.3	1.040
	4	1836	78.7	1.083
II	1	2628	173.8	2.192
	2	2496	173.5	2.190
	3	2400	173.2	2.188
	4	2604	172.8	2.187

Ø 250 MM, BACKWARD CURVED

EC CENTRIFUGAL FAN

Overall Dimensions

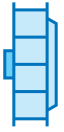

Centrifugal Fan	Weight [kg]
BC-B250B-EC-00	1.3
BC-B250B-EC-01	1.85



Centrifugal Fan with Plug Fan	Weight [kg]
GC-B250B-EC-00	2.37
GC-B250B-EC-01	2.92

BC-B250B-EC-00

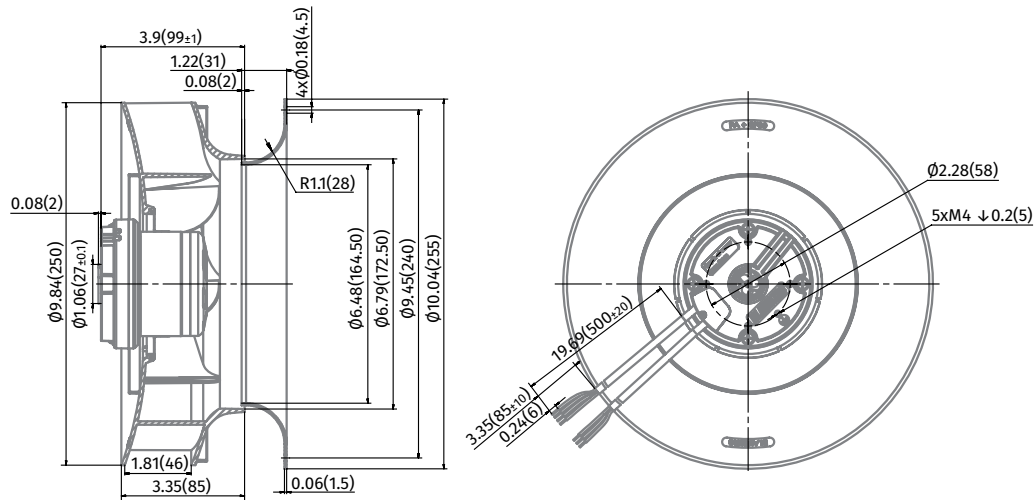

GC-B250B-EC-00

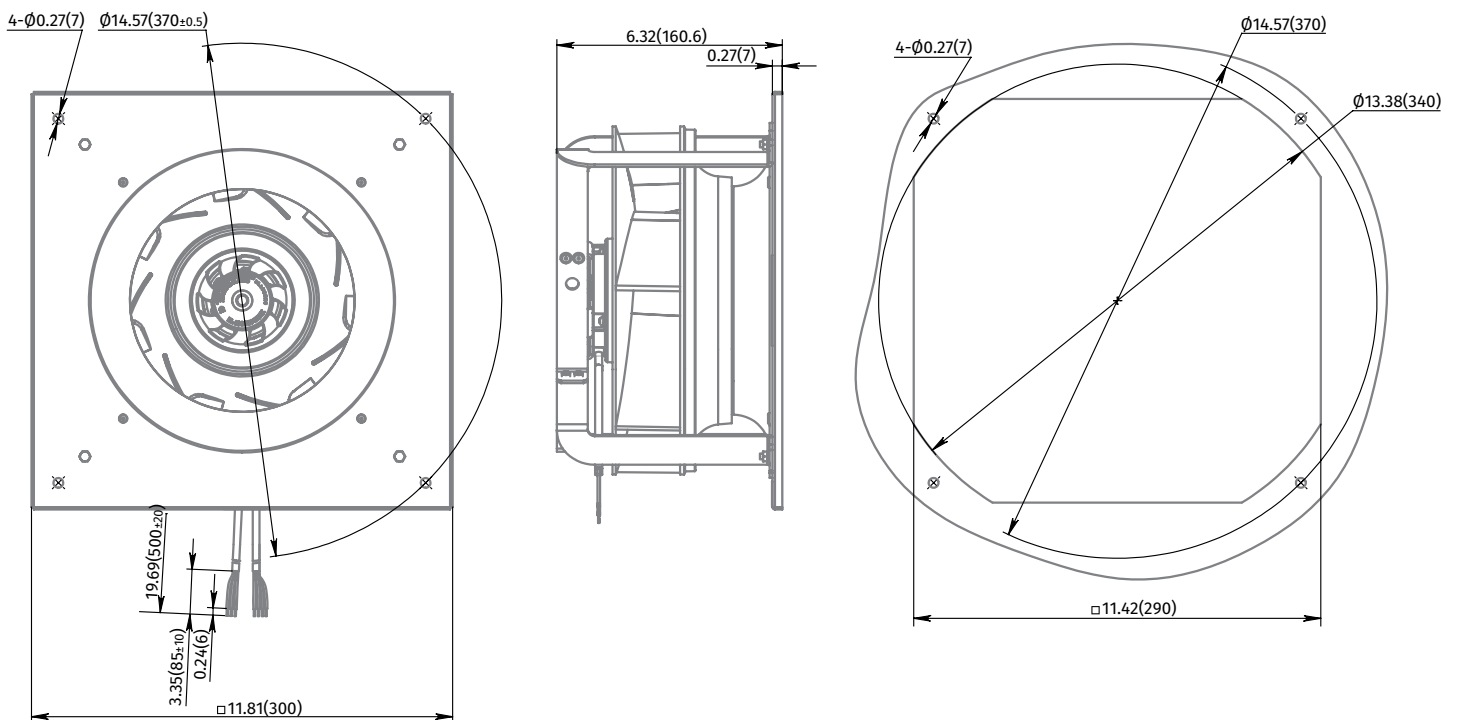

Ø 250 MM, BACKWARD CURVED

EC CENTRIFUGAL FAN

BC-B250B-EC-01

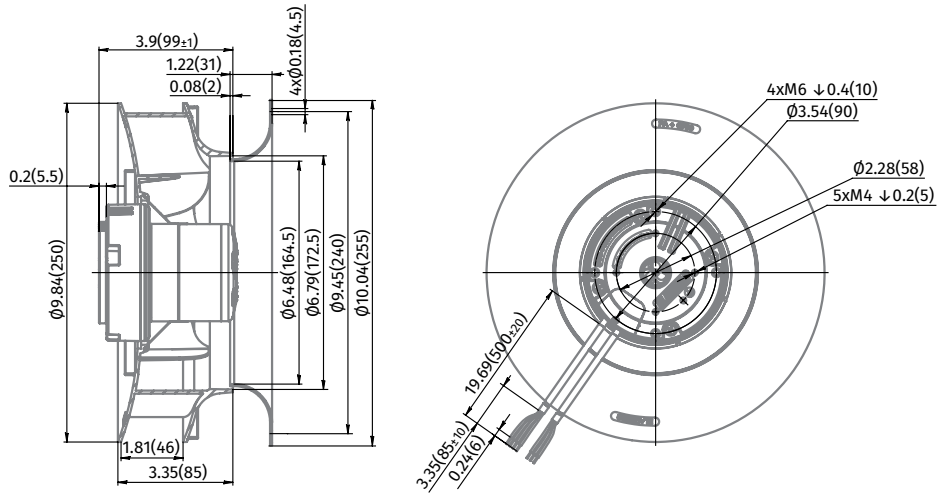

GC-B250B-EC-01

