

# Ø 220 mm, BACKWARD CURVED

# EC CENTRIFUGAL FAN



### Features

- **Materials:** Impeller – PA6+GF30  
Inlet ring – PA6+GF30  
Housing – sheet steel, painted grey
- **Direction of rotation:** clockwise, seen on rotor
- **Type of protection:** IP55
- **Insulation class:** B
- **Mode of operation:** S1
- **Bearing:** ball bearings
- **Motor protection:** self-resetting TOP wired internally



### Technical data

Model	Perform. curve	Nominal voltage [VAC]	Frequency [Hz]	Speed [RPM]	Power input max [W]	Current max [A]	Sound pres. level [dB(A)]	Perm. amb. temp. [°C]	Electrical connection	Inlet ring
*C-B220C-EC-00	I	120	60	2616	97	1.3	72	-25 ... +60	Type "E"/p. 37	p.36
*C-B220C-EC-01	II	120	60	3177	170	2.1	72	-25 ... +60	Type "E"/p. 37	p.36

### PERFORMANCE CURVES

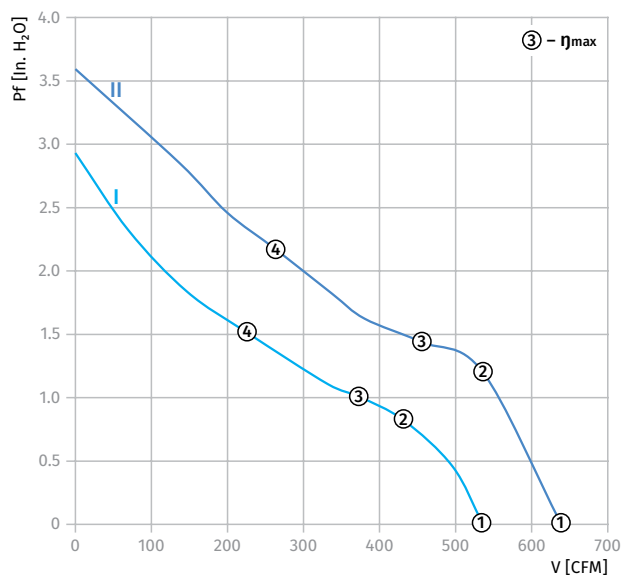

Curve	Point	n [RPM]	Pi [W]	I [A]
I	1	2724	97.5	1.303
	2	2676	97.4	1.304
	3	2616	97.3	1.304
	4	2700	97.3	1.305
II	1	3271	169.6	2.140
	2	3168	168.7	2.138
	3	3177	168.7	2.139
	4	3238	168.5	2.136

# Ø 220 MM, BACKWARD CURVED

# EC CENTRIFUGAL FAN

## Overall Dimensions

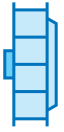

Centrifugal Fan	Weight [kg]
BC-B220C-EC-00	1.15
BC-B220C-EC-01	1.7



Centrifugal Fan with Plug Fan	Weight [kg]
GC-B220C-EC-00	2
GC-B220C-EC-01	2.55

### BC-B220C-EC-00

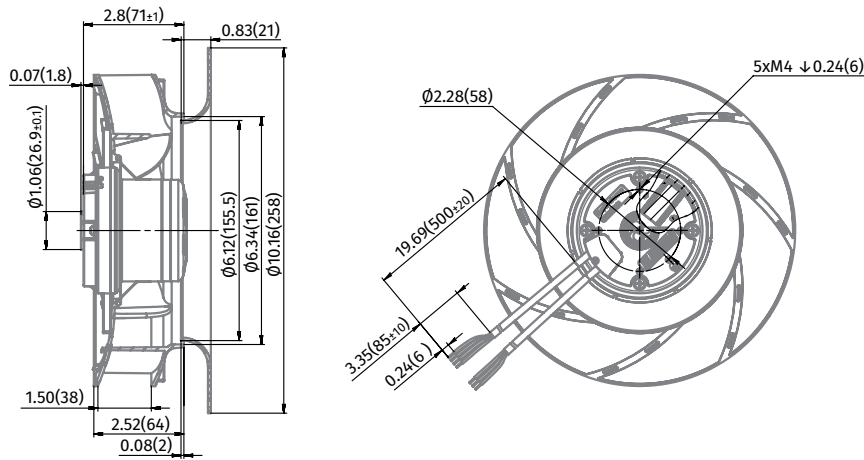

### GC-B220C-EC-00

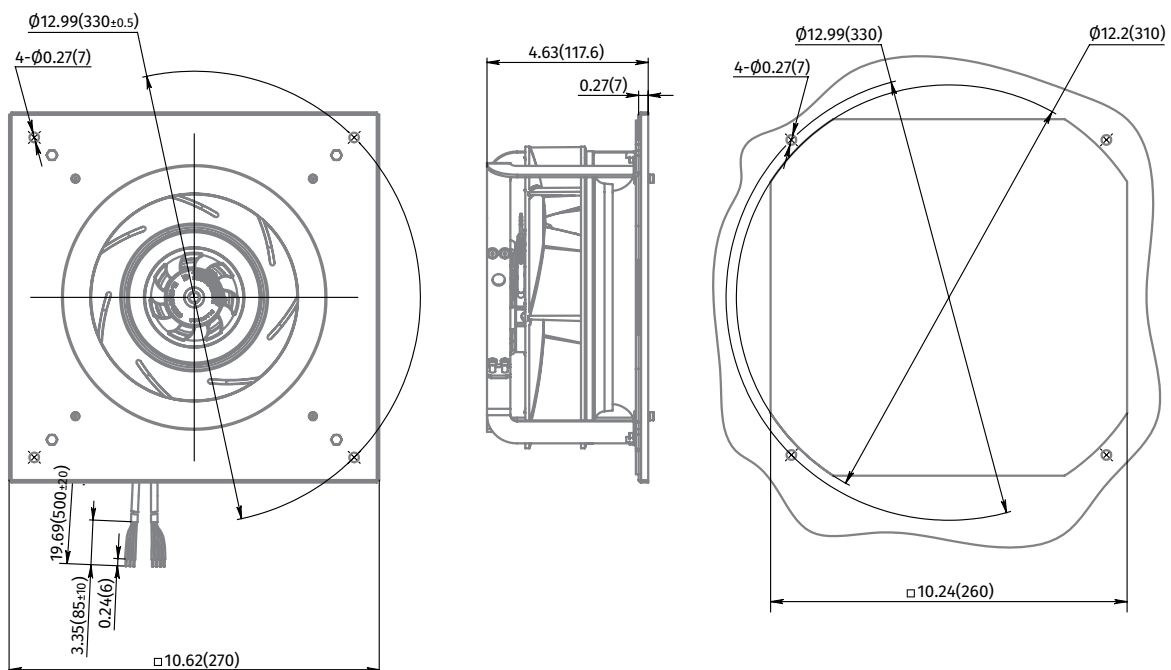

Ø 220 MM, BACKWARD CURVED

EC CENTRIFUGAL FAN

BC-B220C-EC-01

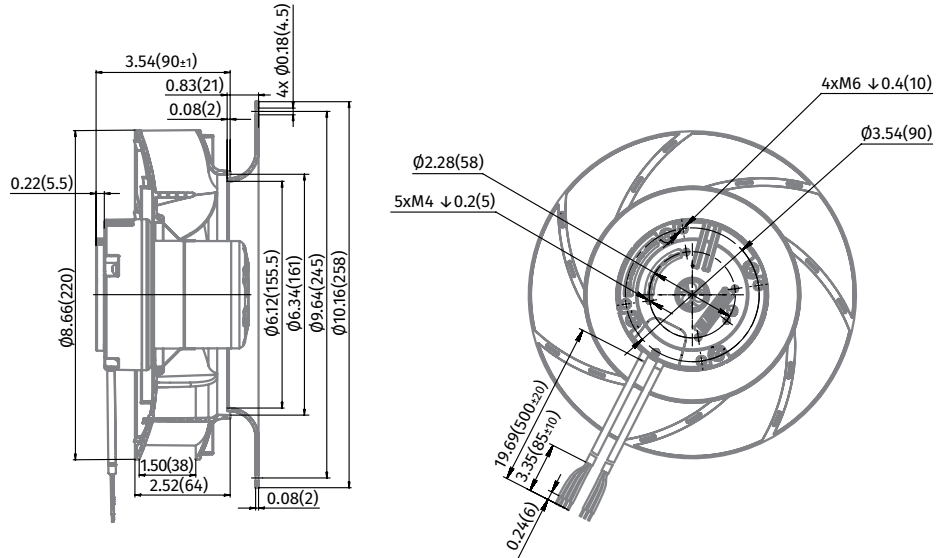

GC-B220C-EC-01

