

Ø 225 MM, BACKWARD CURVED

EC CENTRIFUGAL FAN

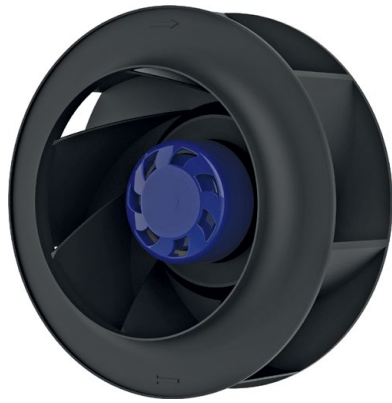

Features

- Speed control: 0 ~ 10 V DC/PWM
- Impeller material: PA plastic + 30 % glass fiber
- Direction of rotation: clockwise, seen on rotor
- Type of protection: IP55
- Insulation class: B
- Mode of operation: continuous operation (S1)
- Bearing: ball bearings
- Motor protection: self-resetting TOP wired internally



Technical data

Model	Perform. curve	Nominal voltage [VAC]	Frequency [Hz]	Speed [RPM]	Power input max [W]	Current max [A]	Sound pres. level [dBA]	Perm. amb. temp. [°C]	Capacitor [µF/VDB]	Electrical connection
BL-B225D-EC-00	I	230	50/60	2100	85	0.70	68	-25 ... +60	-	E

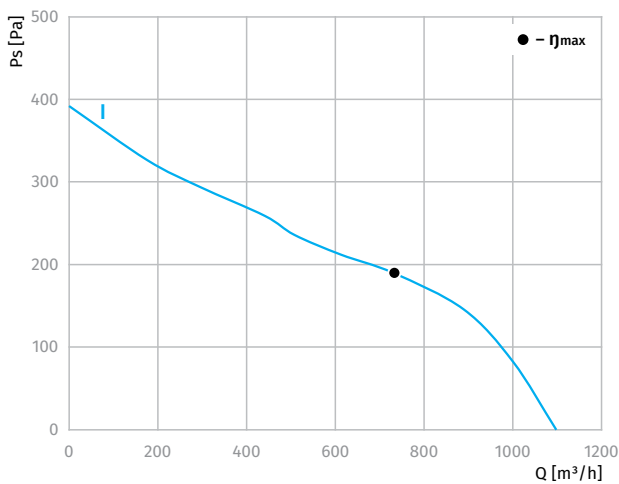

Overall dimensions

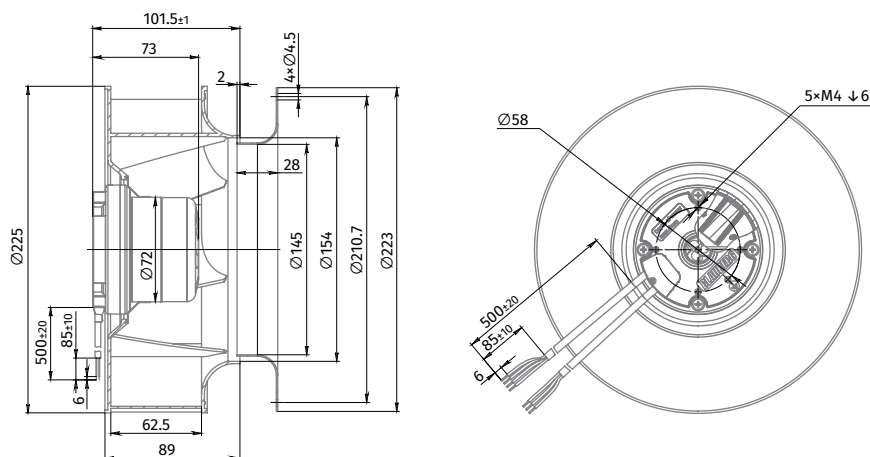

Ø 225 MM, BACKWARD CURVED

EC CENTRIFUGAL FAN



Features

- Speed control: 0 ~ 10 V DC/PWM
- Impeller material: PA plastic + 30 % glass fiber
- Direction of rotation: clockwise, seen on rotor
- Type of protection: IP55
- Insulation class: B
- Mode of operation: continuous operation (S1)
- Bearing: ball bearings
- Motor protection: self-resetting TOP wired internally



Technical data

Model	Perform. curve	Nominal voltage [VAC]	Frequency [Hz]	Speed [RPM]	Power input max [W]	Current max [A]	Sound pres. level [dBA]	Perm. amb. temp. [°C]	Capacitor [µF/VDB]	Electrical connection
BL-B225D-EC-01	I	230	50/60	3800	165	1.10	72	-25 ... +60	-	E

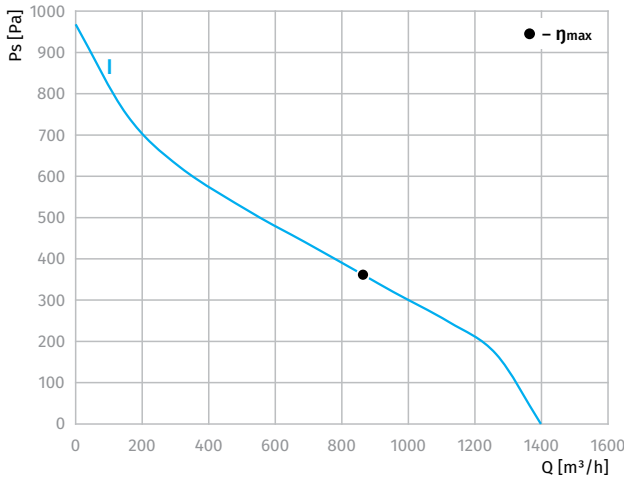

Overall dimensions

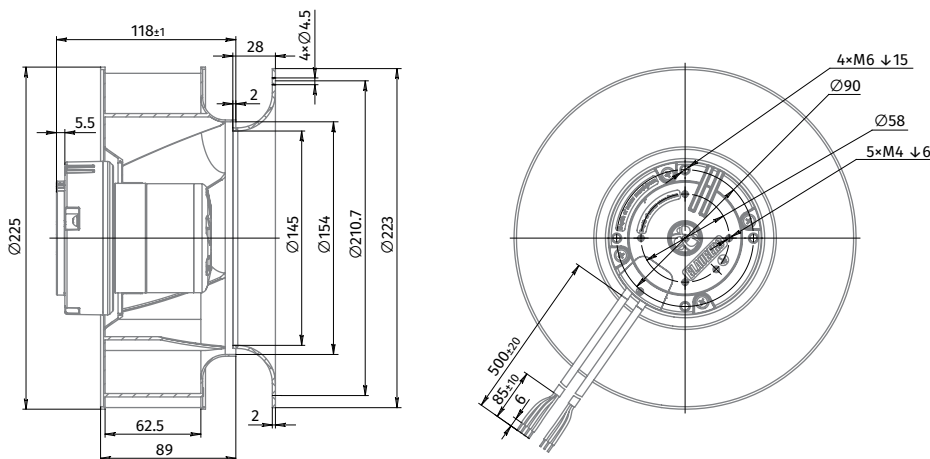

BACKWARD CURVED AC CENTRIFUGAL FANS

BACKWARD CURVED EC CENTRIFUGAL FANS

FORWARD CURVED AC CENTRIFUGAL FANS

FORWARD CURVED EC CENTRIFUGAL FANS

FORWARD CURVED AC BLOWERS

FORWARD CURVED EC BLOWERS

BACKWARD CURVED EC BLOWERS