

AC axial fan (welded ø 200 mm, 9 blades)



- Impeller material: steel powder coated, welded
- Direction of rotation: counterclockwise, seen on rotor
- Type of protection: IP54
- Insulation class: B
- Mode of operation: continuous operation (S1)
- Bearing: ball bearings
- Motor protection: self-resetting TOP wired internally



Technical data

Type	Nominal voltage [VAC]	Frequency [Hz]	Speed [RPM]	Power input [W]	Current [A]	Sound pressure level [dB(A)]	Perm. amb. temperature [°C]	Capacitor [µF/VDB]	Electrical connection
BL-A200B-2E-A01-B3	230	50	2580	62	0.29	56	-25...+40	1.5/450	A
		60	2760	81	0.36	60			
BL-A200B-4E-A01-B3	230	50	1400	40	0.21	43	-25...+40	1.5/450	A
		60	1500	50	0.23	45			

Overall dimensions

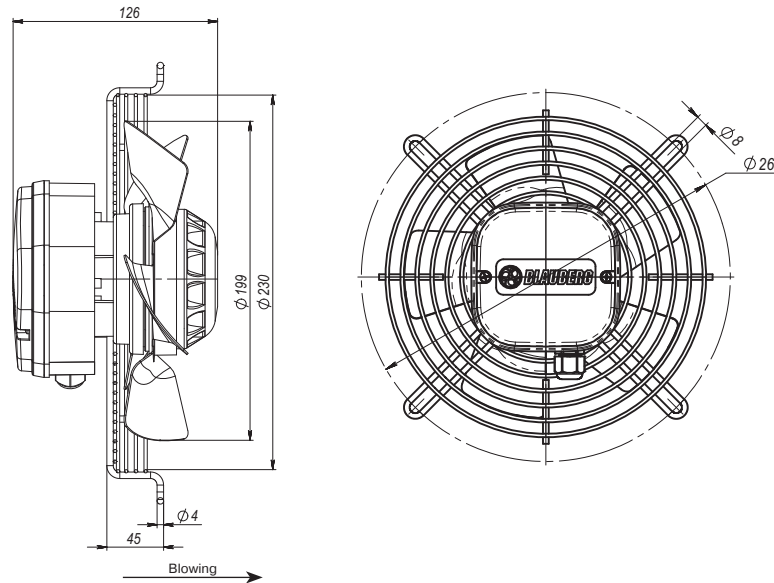

Performance curves

