



BLAUBERG
Motoren



ZENTRI-PAC SERIES

CATALOGUE 2018

CONTENTS

About Blauberg Group	2
Fan Motors	4
Zentri-PAC Series	6
Type Key	8
EC Centrifugal Fan	9
AC Centrifugal Fan	29
Inlet Rings	36
Electrical connection diagram	37

BLAUBERG

GROUP



Blauberg Group manufactures and sells a complete range of hi-tech energy-efficient ventilation equipment offering a balanced mix of innovative technology, contemporary design and traditional German quality.

The group's main products include domestic fans, single-room ventilation units, heat recovery units, industrial fans and air handling units, parts and accessories for customized system configurations as well as bespoke ventilation solutions. Due to our product diversity, we do our best to meet the individual needs of our clients in various countries with the best combination of price and quality.

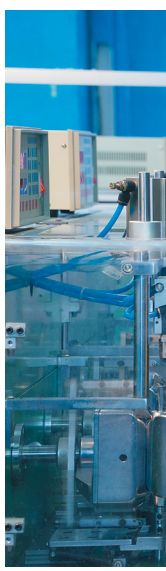



Blaubeerg Motoren was born in Munich, Germany, like own direction of fans and motors manufacturing and integral part of Blaubeerg Group.



Starting with manufacturing AC motors with external rotors for own needs, for now Blaubeerg Motoren produce wide range of motors and fans with EC and AC technology for clients all around the world. It includes axial fans, backward curved fans, forward curved fans, blowers.

We are proud to be presented in products of our clients – world famous manufactures of ventilation, heat, home appliance and other equipment, and be part of their success.



For now Blaubeerg Motoren have R&D (research and development) center in Munich (Germany), as well as main testing laboratories for products and factories in Germany (Munich), Ukraine (Kiev) and Poland.

Every day we are working with our passion and respect to technology and engineering to make our products better – more responsive to needs and expectations of our clients.

With traditional German quality, we are focused on developing and improving best one and newest technology – in our own manufacturing and in our products.

WE ARE CLIENT-ORIENTED COMPANY AND TRY TO BE BEST ONE FOR OUR CLIENTS IN SEGMENTS WE ARE PRESENT.

FAN MOTORS

THE MOTORS ARE POWERED BY DIRECT OR ALTERNATING CURRENT.

- A direct current motor is powered by a direct power supply.
- An alternating current motor is powered by an alternating power supply.

Alternating current motors are the most widely used motors because the basic electric grid in the country has alternating power supply.

ALTERNATING CURRENT MOTORS HAVE TWO TYPES:

- **Synchronous** electric motors are alternating current motors with a rotor that rotates synchronously with a magnetic field;
- **Asynchronous** electric motors are alternating current motors with the magnetic field frequency exceeding the motor rotation speed.

Asynchronous motors

Nowadays the asynchronous electric motors find wide application.

Asynchronous electric motors consist of two basic components, the stator and the rotor.

The stator is a fixed motor component. On the inner side the stator has some slots for laying of three-phase cable winding that is powered by three-phase current. The rotor is a rotating part of the motor and also has slots for inserting the cable winding. The rotor and the stator are assembled of separate 0.35-0.5 mm thick electrotechnical steel pressed plates.

Separate plates are insulated from each other with a varnish layer. The air gap between the stator and the rotor is kept as low as possible: 0.3-0.35 mm for low capacity machinery and 1.0-1.5 for more powerful machinery.

Depending on the rotor design the asynchronous motors are available in short circuit modification and phased modifications. Short circuit motors are the most widely used motors because of their simple design and easy operation. The three-phase stator winding is inserted inside the slots and consists of a number of interconnected coils. Each coil consists of one or several turns which are insulated against each other and against the slot walls.

THE ASYNCHRONOUS ELECTRIC MOTOR WITH SHORT CIRCUIT ROTOR HAS THE FOLLOWING ADVANTAGES:

- Permanent speed at various loads.
- Resistance to short-term mechanical overloads.
- Easy structure.
- Easy start-up.
- Higher $\cos \phi$ and efficiency compared to electric motors with phased rotor.

The design of the asynchronous electric motor with external rotor is similar to that of the standard asynchronous electric motor.

The only difference is the position of the rotor. The electric rotor motor is located inside the stator winding and the stator with turns is located in the electric motor center. This configuration provides a compact size of the ventilation unit. The electric motor shaft is carried by ball bearings fixed inside the stator and the impeller is fixed in the rotor casing. Such a design provides air cooling of the electric motor which makes it applicable for a wide temperature range. The electric motors are assembled with the impellers and are subjected to static and dynamic balancing in compliance with DIN ISO 1940. The motors have an integrated overheating protection with automatic restart.

All the motors have 100 % controllable speed range. Speed control is performed with a transformer or electronic devices. Explosionproof motors are controlled exclusively by transformers within 25% up to 100% of the rated voltage range. Speed control is performed by voltage change whereas the frequency in the grid remains the same. The electric motor speed is smoothly decreased as power voltage drops or is increased as power voltage rises. The motor can also be controlled with a frequency converter.

ADVANTAGES OF THE ASYNCHRONOUS ELECTRIC MOTOR WITH EXTERNAL ROTOR:

- Long service life.
- Light weight and small overall dimensions.
- Easy assembly and installation.
- Aligned impeller and electric motor.
- Regulated air capacity.
- Low energy demand during start-up.



EC motors

The electric motor with high-efficient EC motor is a synchronous direct current motor driven by an electronic commutating unit (controller). It has no friction and wearing parts as a collector or brushes, unlike the standard motor. The function of these parts is performed with the maintenance-free electronic circuit of the EC controller.

The EC technology is the state-of-the-art method for arrangement of energy saving and high efficient ventilation.

The energy demand of EC motors is by 50% less as compared to standard motors and efficiency reaches 90%.

These new electric motors are featured with high performance, low noise level and controllable total speed range. The electronic EC-controller enables some other smart functions, e.g. fan control according to measured temperature, pressure and other parameters.

A unique software ensures high control accuracy for fans integrated into a single network. Parameters of a single fan integrated into a common network may be centrally corrected to match the ventilation system parameters. All the system parameters are displayed online on a computer. This enables programming individual operation modes of each fan in the system. This technology enables also programming custommade settings to meet individual customer requirements.



ADVANTAGES OF EC MOTORS:

- Efficient performance at any rotation speed of the fan, including very low speed.
- Low heat emission.
- Small overall dimensions of the unit due to external rotor design.
- Maximum fan rotation speed does not depend on frequency in the grid.
- The fan is suitable for connection both to 50 Hz and 60 Hz power mains.
- High efficiency at low rotation speed.
- Energy demand is by 1/3 less as compared to standard motors.
- Data interchange between PC and fan for parameter setting and control.
- Integration of all fans into a unified system and their centralized control.

ZENTRI-PAC SERIES

The new line of Zentri-PAC fans embodies the philosophy of Blauberg Motoren:

"To keep pace with the time we have to outperform and overachieve, we have to push to the forefront of science and technology, follow global trends and embark on a never-ending quest for innovation".

Responding to the popular demand and customer feedback we have created a special series of centrifugal fans which feature backward-curved blades and benefit from improved impeller design and reliable high-performance EC motors.

The new series includes the most popular fan models, which comply with all modern aerodynamic and energy efficiency requirements with the impeller diameter ranging from 133 mm to 250 mm.

The impeller is made of a composite high-tech plastic material with fibreglass reinforcement elements for higher rigidity and stress resistance.

Specially profiled blades are the result of extensive CAD design and long hours of wind tunnel testing help reduce airflow losses and improve the aerodynamic characteristics of fans. Smooth and uniform airflow spread reduces operating noise.



Plug Fan casing series

For further improvement of the ease and convenience of fan installation Blauberg Motoren has come up with the latest solution, which enables using Zentri-PAC fans with Plug Fan type casings produced in-house.

PLUG FAN SYSTEM HAS A RANGE OF IMMEDIATE ADVANTAGES:

- Retaining an optimum air flow
- Compact footprint and space-saving design
- Convenient and simple installation
- Use and replacement of individual unit components as necessary for reduced maintenance costs
- Installation at any angle

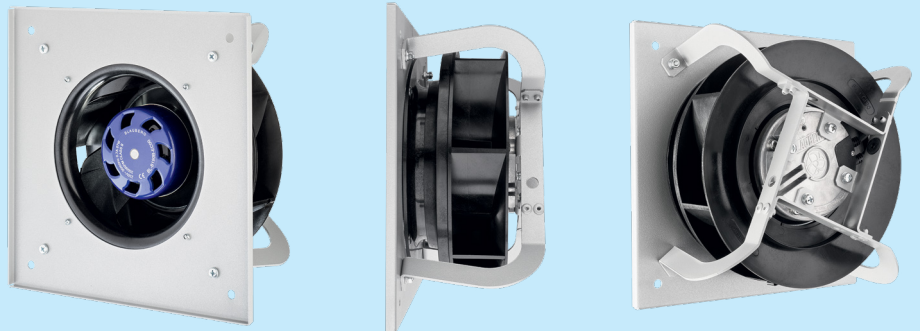

ZENTRI-PAC SERIES FANS COME WITH A HOST OF BENEFITS:

- New series of EC motors for high performance and low power consumption
- Compact footprint and easy retrofitting
- High efficiency (up to 95%)
- Control over the entire speed range for optimum performance
- Improved aerodynamic and acoustic performance thanks to the updated impellers
- Plug Fan casing system compatibility

The well-proven series of our AC fans compatible with Plug Fan casings has also received the new impellers for improved performance.

TYPE KEY

EC centrifugal fans

BL-B190A-EC00

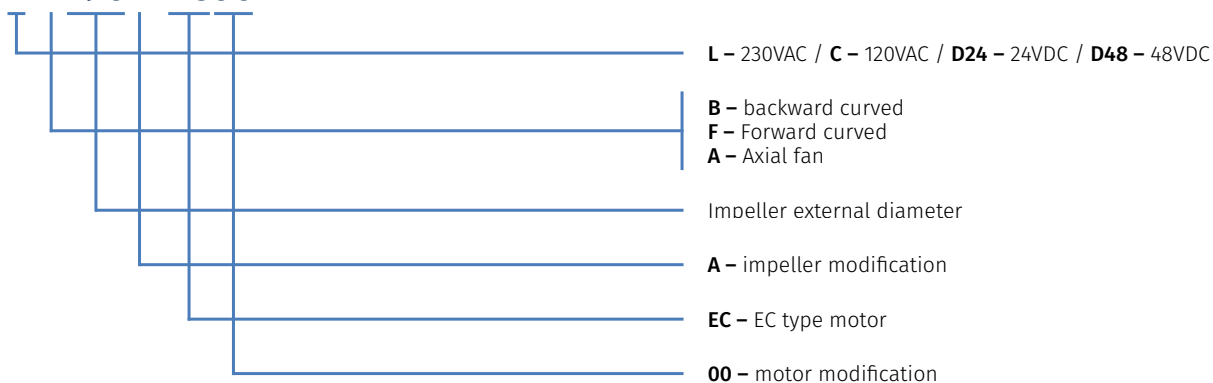

AC centrifugal fans

BL-B 190 A-2 E-A 0 1-01(OR B1)

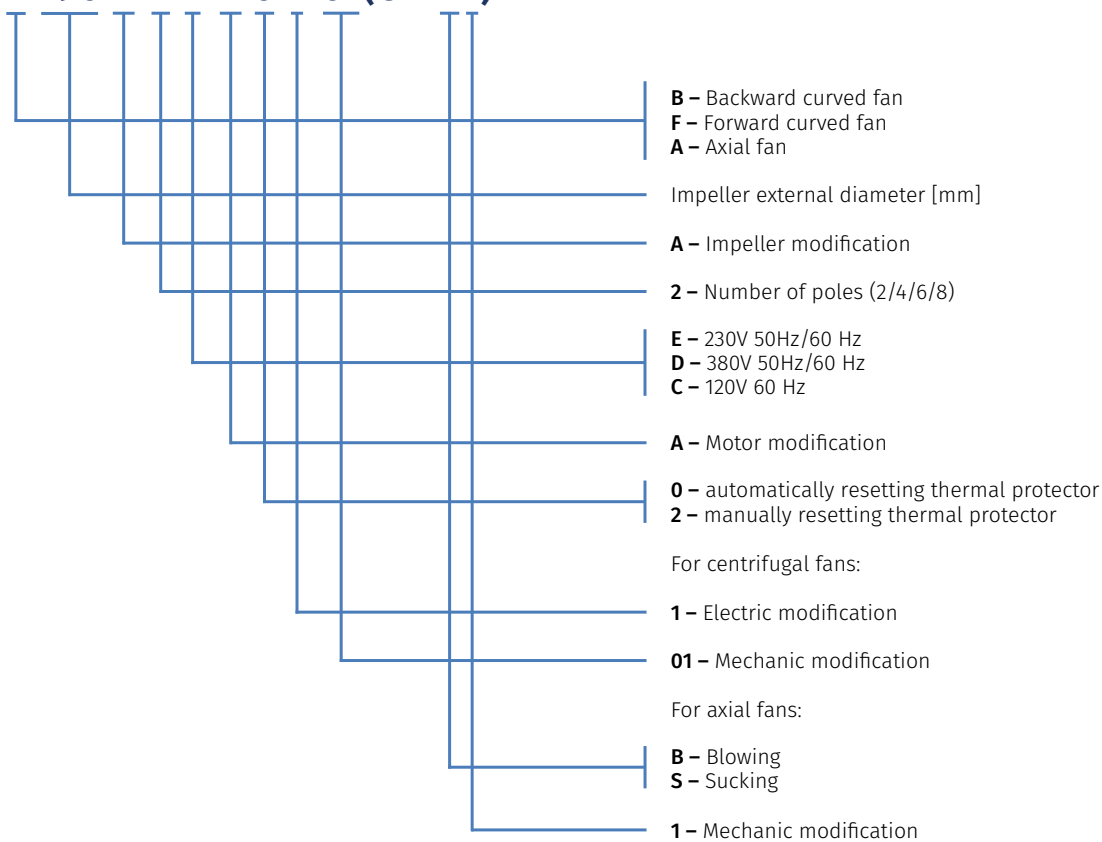

EC CENTRIFUGAL FANS

Ø 133 10

Ø 175 12

Ø 190 14

Ø 220 18

Ø 225 22

Ø 250 26

Ø 133 mm, BACKWARD CURVED

EC CENTRIFUGAL FAN

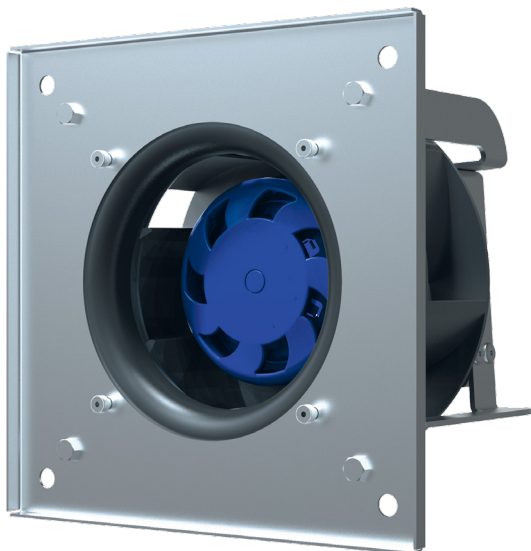

Features

- **Materials:** Impeller – PA6+GF20
Inlet ring – PA6+GF20
Housing – sheet steel, painted grey
- **Direction of rotation:** clockwise, seen on rotor
- **Type of protection:** IP55
- **Insulation class:** B
- **Mode of operation:** S1
- **Bearing:** ball bearings
- **Motor protection:** fuse



Technical data

Model	Perform. curve	Nominal voltage [VAC]	Frequency [Hz]	Speed [RPM]	Power input max [W]	Current max [A]	Sound pres. level [dB(A)]	Perm. amb. temp. [°C]	Electrical connection	Inlet ring
*C-B133A-EC-00	I	120	60	4416	48	0.7	72	-25 ... +60	Type "E"/p. 37	p.36

PERFORMANCE CURVES

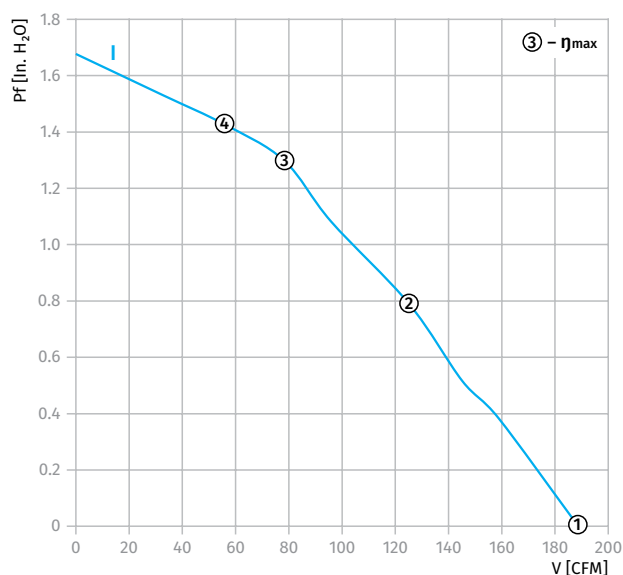

Curve	Point	n [RPM]	Pi [W]	I [A]
I	1	4380	45.0	0.655
	2	4344	47.5	0.691
	3	4416	41.5	0.614
	4	4452	38.6	0.576

Ø 133 MM, BACKWARD CURVED

EC CENTRIFUGAL FAN

Overall Dimensions



Centrifugal Fan	Weight [kg]
BC-B133A-EC-00	1



Centrifugal Fan with Plug Fan	Weight [kg]
GC-B133A-EC-00	1.4

BC-B133A-EC-00

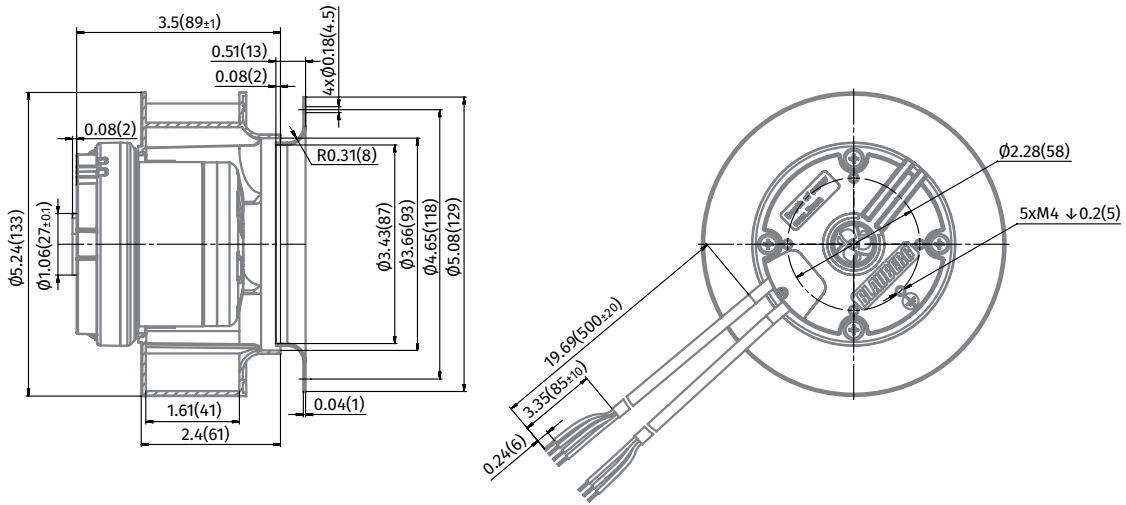

GC-B133A-EC-00

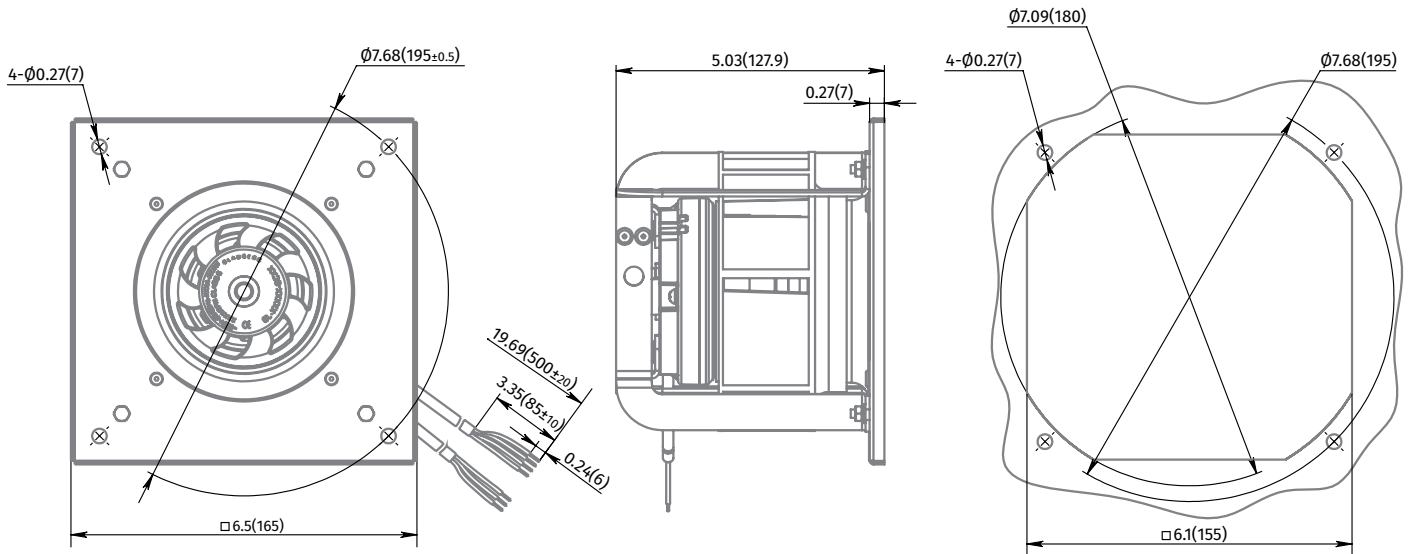

Ø 175 mm, BACKWARD CURVED

EC CENTRIFUGAL FAN

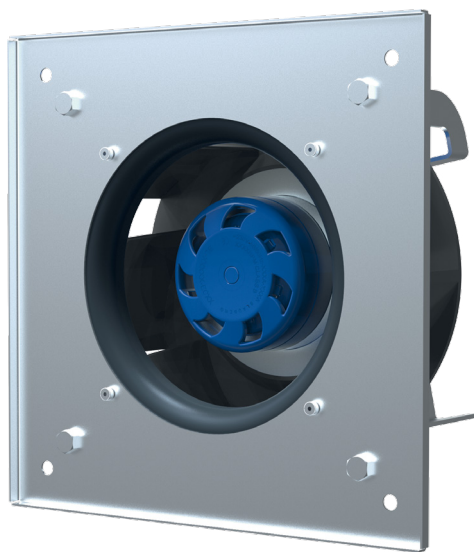

Features

- **Materials:** Impeller – PA6+GF20
Inlet ring – PA6+GF20
Housing – sheet steel, painted grey
- **Direction of rotation:** clockwise, seen on rotor
- **Type of protection:** IP55
- **Insulation class:** B
- **Mode of operation:** S1
- **Bearing:** ball bearings
- **Motor protection:** fuse



Technical data

Model	Perform. curve	Nominal voltage [VAC]	Frequency [Hz]	Speed [RPM]	Power input max [W]	Current max [A]	Sound pres. level [dB(A)]	Perm. amb. temp. [°C]	Electrical connection	Inlet ring
*C-B175A-EC-00	I	120	60	3252	57	0.82	72	-25 ... +60	Type "E"/p. 37	p.36

PERFORMANCE CURVES

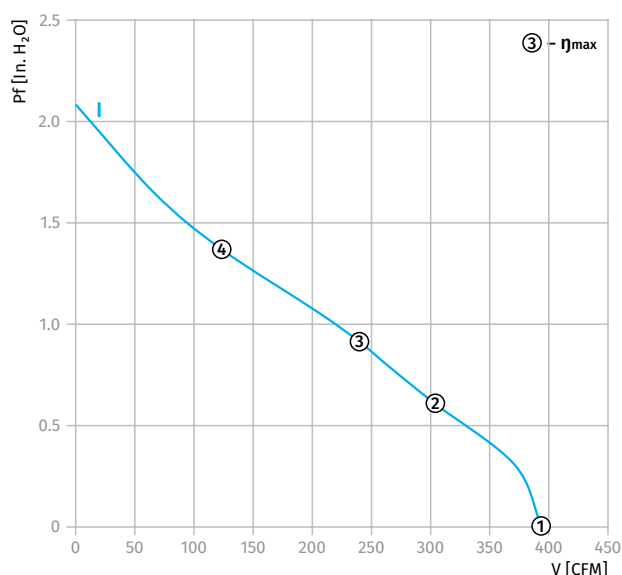

Curve	Point	n [RPM]	Pi [W]	I [A]
I	1	3552	57.1	0.816
	2	3300	57.1	0.814
	3	3252	57.1	0.814
	4	3372	57.1	0.813

Ø 175 MM, BACKWARD CURVED

EC CENTRIFUGAL FAN

Overall Dimensions



Centrifugal Fan	Weight [kg]
BC-B175A-EC-00	1.1



Centrifugal Fan with Plug Fan	Weight [kg]
GC-B175A-EC-00	1.65

BC-B175A-EC-00

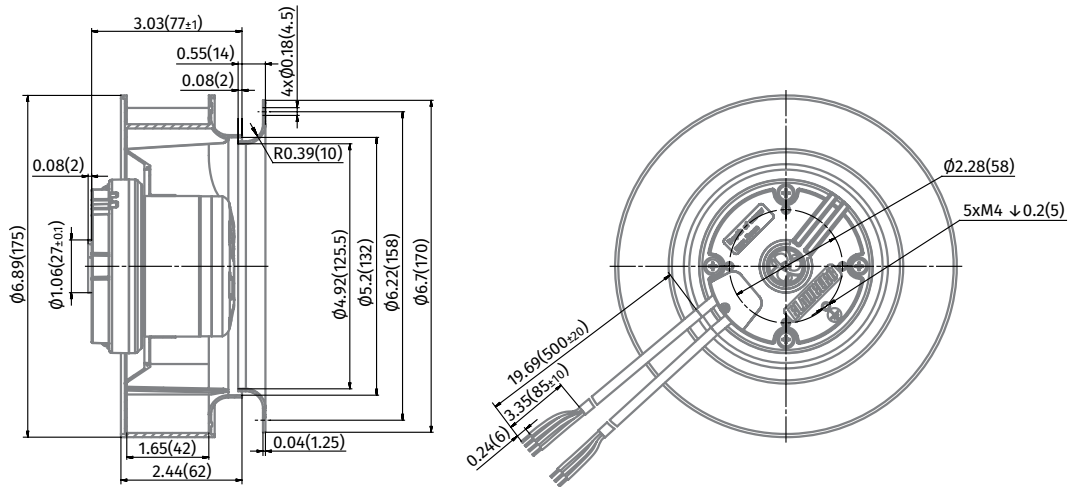

GC-B175A-EC-00

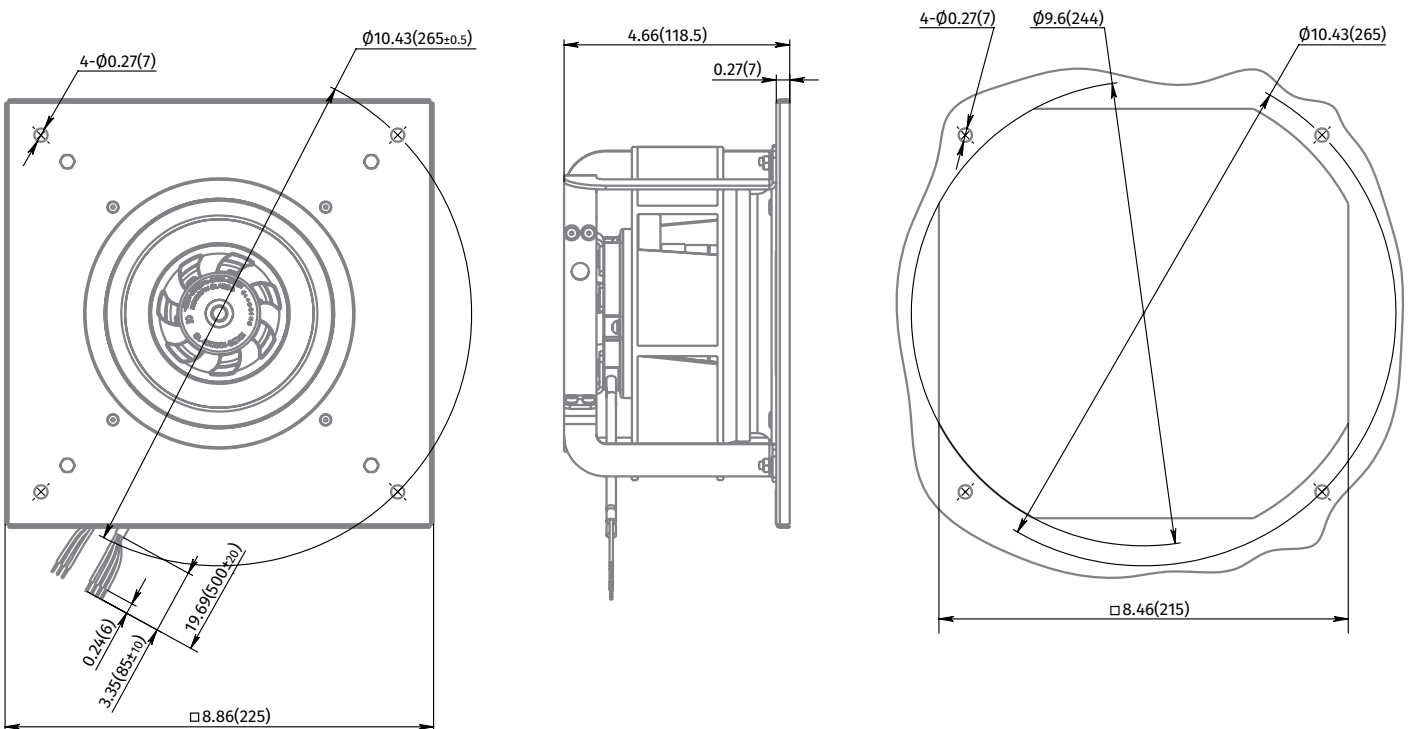

Ø 133

Ø 175

Ø 190

Ø 220

Ø 225

Ø 250

Ø 190

Ø 220

Ø 250

Ø 190 mm, BACKWARD CURVED

EC CENTRIFUGAL FAN



Features

- **Materials:** Impeller – PA6+GF20
Inlet ring – PA6+GF20
Housing – sheet steel, painted grey
- **Direction of rotation:** clockwise, seen on rotor
- **Type of protection:** IP55
- **Insulation class:** B
- **Mode of operation:** S1
- **Bearing:** ball bearings
- **Motor protection:** fuse



Technical data

Model	Perform. curve	Nominal voltage [VAC]	Frequency [Hz]	Speed [RPM]	Power input max [W]	Current max [A]	Sound pres. level [dB(A)]	Perm. amb. temp. [°C]	Electrical connection	Inlet ring
*C-B190B-EC-00	I	120	60	3180	84	1.14	72	-25 ... +60	Type "E"/p. 37	p.36
*C-B190B-EC-03	II	120	60	4120	166	2.2	72	-25 ... +60	Type "E"/p. 37	p.36

PERFORMANCE CURVES

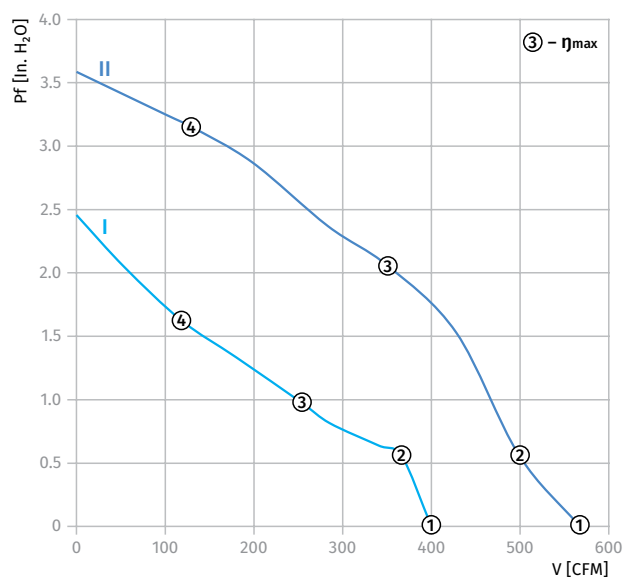

Curve	Point	n [RPM]	Pi [W]	I [A]
I	1	3348	84.70	1.117
	2	3240	84.50	1.128
	3	3180	84.20	1.137
	4	3348	84.10	1.140
II	1	4370	166.28	2.207
	2	4270	166.18	2.206
	3	4120	166.00	2.204
	4	4590	165.80	2.201

Ø 190 MM, BACKWARD CURVED

EC CENTRIFUGAL FAN

Overall Dimensions



Centrifugal Fan	Weight [kg]
BC-B190B-EC-00	1.1
BC-B190B-EC-03	1.65



Centrifugal Fan with Plug Fan	Weight [kg]
GC-B190B-EC-00	1.75
GC-B190B-EC-03	2.3

BC-B190B-EC-00

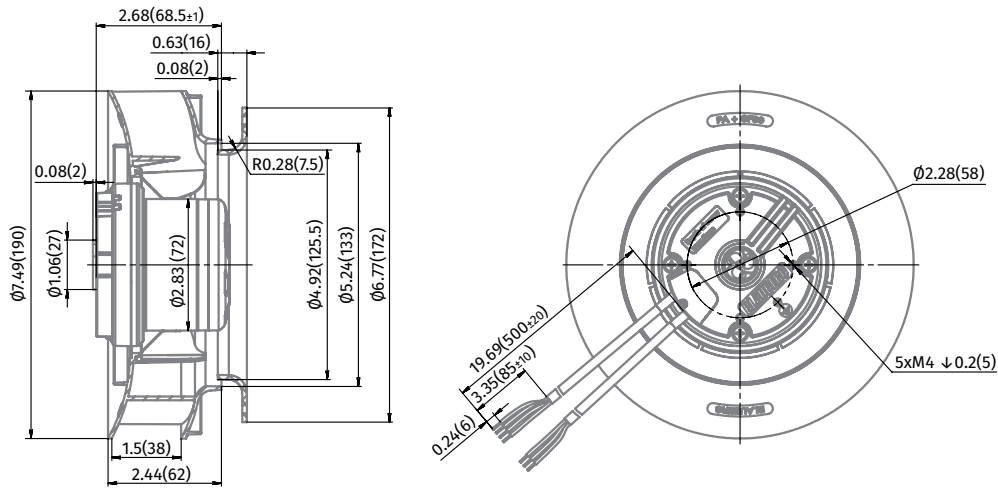

GC-B190B-EC-00

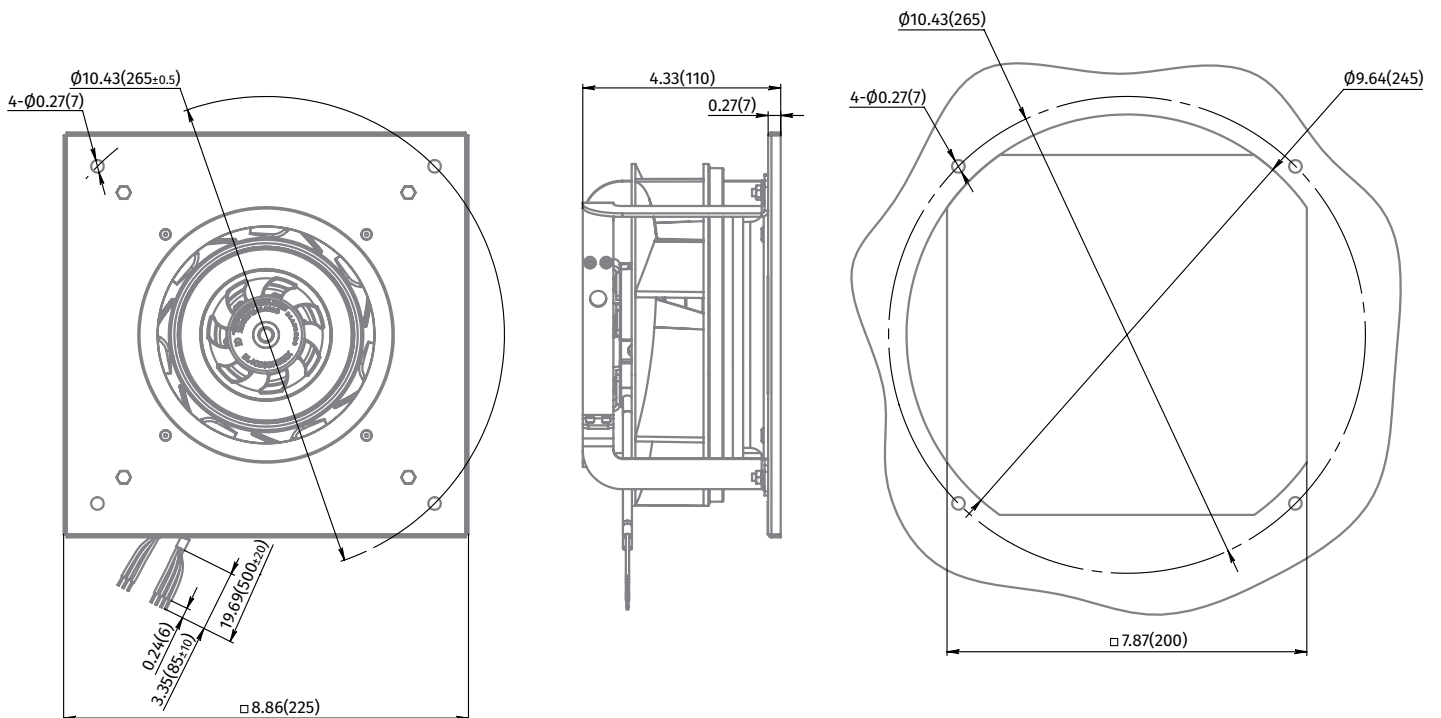

Ø 190 MM, BACKWARD CURVED

EC CENTRIFUGAL FAN

BC-B190B-EC-03

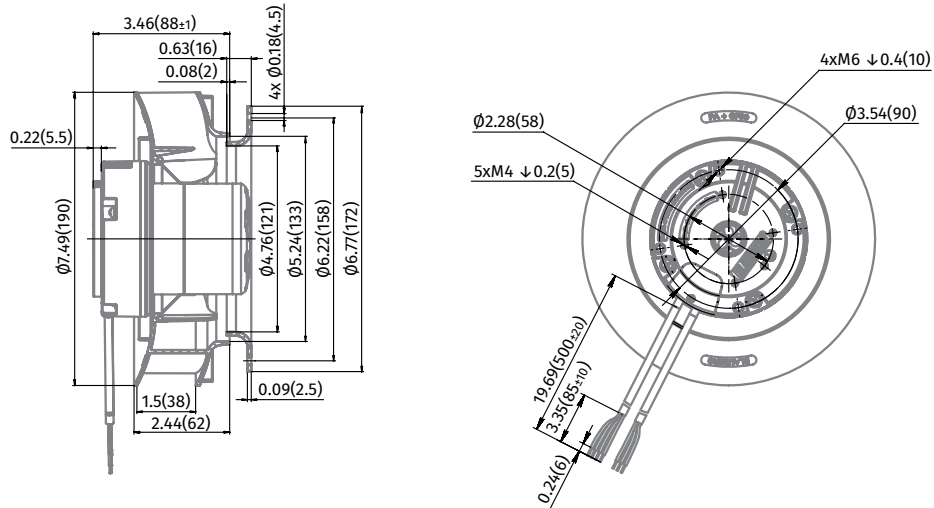

GC-B190B-EC-03

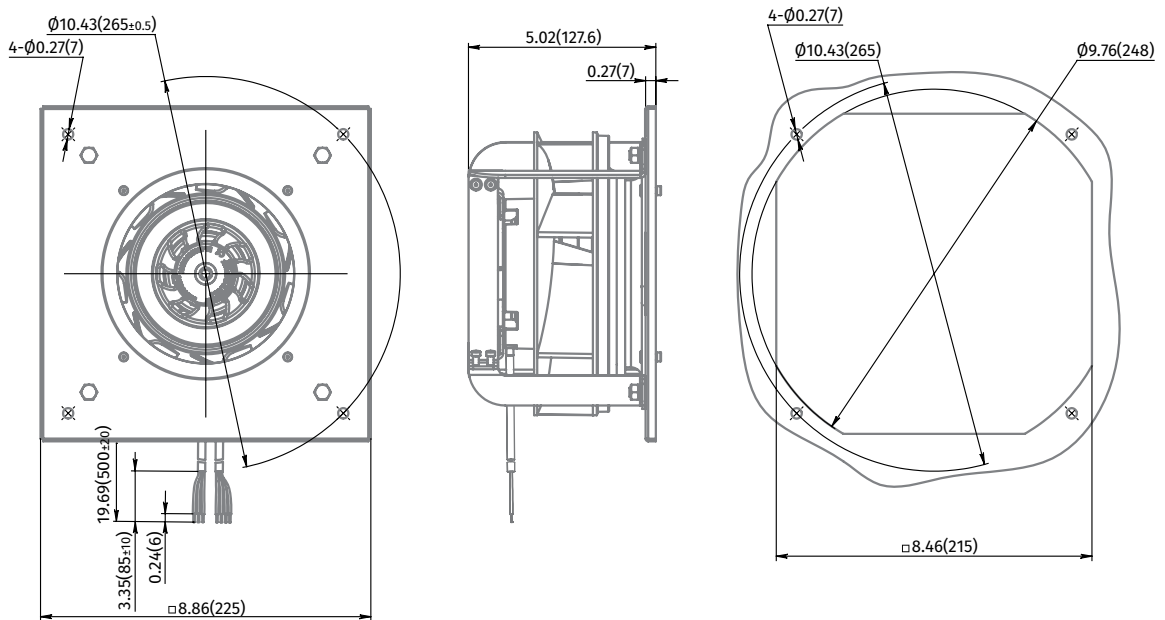

Ø 190 MM, BACKWARD CURVED

EC CENTRIFUGAL FAN

Ø 133

Ø 175

Ø 190

Ø 220

Ø 225

Ø 250

Ø 190

Ø 220

Ø 250

Ø 220 mm, BACKWARD CURVED

EC CENTRIFUGAL FAN



Features

- **Materials:** Impeller – PA6+GF20
Inlet ring – PA6+GF20
Housing – sheet steel, painted grey
- **Direction of rotation:** clockwise, seen on rotor
- **Type of protection:** IP55
- **Insulation class:** B
- **Mode of operation:** S1
- **Bearing:** ball bearings
- **Motor protection:** fuse



Technical data

Model	Perform. curve	Nominal voltage [VAC]	Frequency [Hz]	Speed [RPM]	Power input max [W]	Current max [A]	Sound pres. level [dB(A)]	Perm. amb. temp. [°C]	Electrical connection	Inlet ring
*C-B220C-EC-00	I	120	60	2616	97	1.3	72	-25 ... +60	Type "E"/p. 37	p.36
*C-B220C-EC-01	II	120	60	3177	170	2.1	72	-25 ... +60	Type "E"/p. 37	p.36

PERFORMANCE CURVES

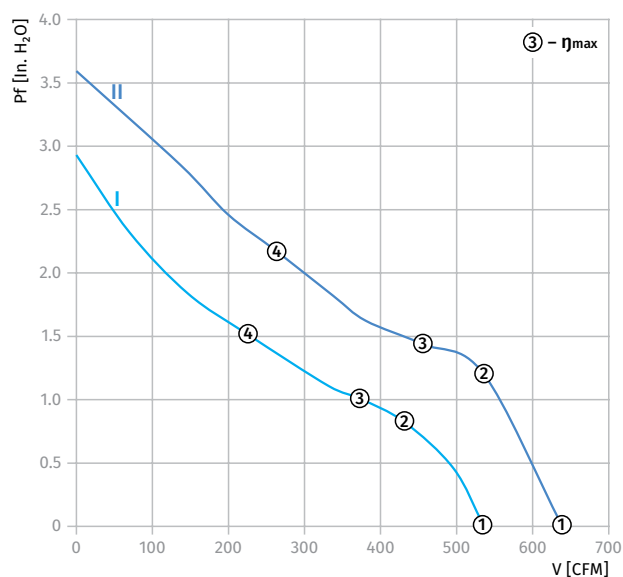

Curve	Point	n [RPM]	Pi [W]	I [A]
I	1	2724	97.5	1.303
	2	2676	97.4	1.304
	3	2616	97.3	1.304
	4	2700	97.3	1.305
II	1	3271	169.6	2.140
	2	3168	168.7	2.138
	3	3177	168.7	2.139
	4	3238	168.5	2.136

Ø 220 mm, BACKWARD CURVED

EC CENTRIFUGAL FAN

Overall Dimensions

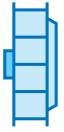

Centrifugal Fan	Weight [kg]
BC-B220C-EC-00	1.15
BC-B220C-EC-01	1.7



Centrifugal Fan with Plug Fan	Weight [kg]
GC-B220C-EC-00	2
GC-B220C-EC-01	2.55

BC-B220C-EC-00

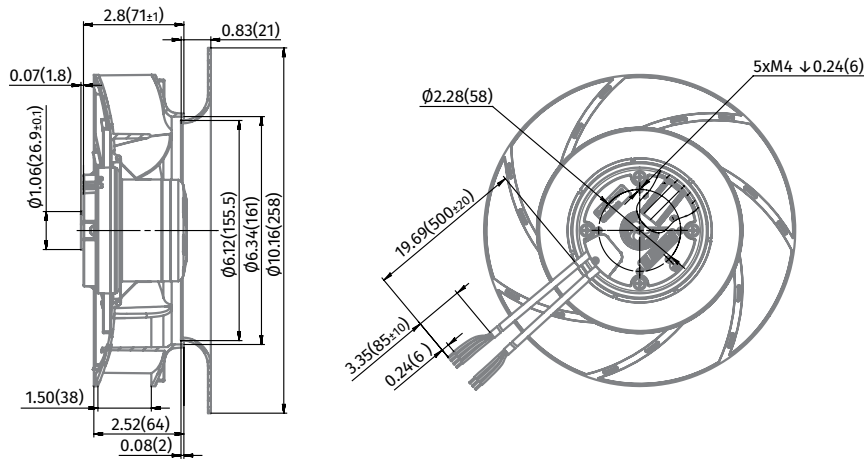

GC-B220C-EC-00

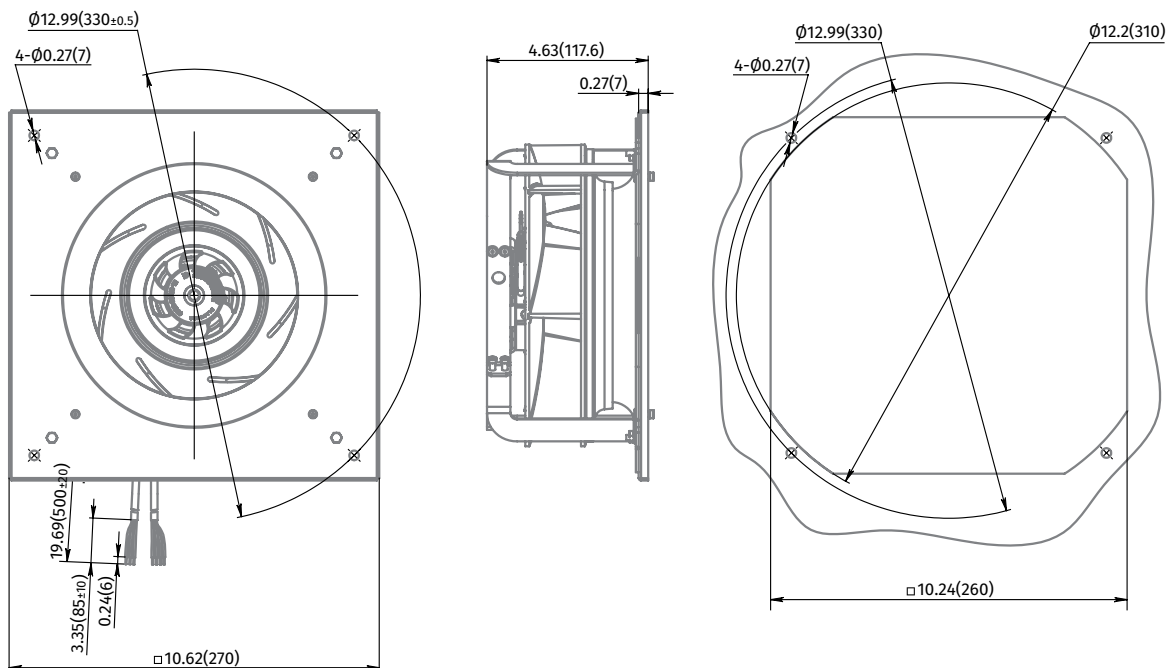

Ø 220 mm, BACKWARD CURVED

EC CENTRIFUGAL FAN

BC-B220C-EC-01

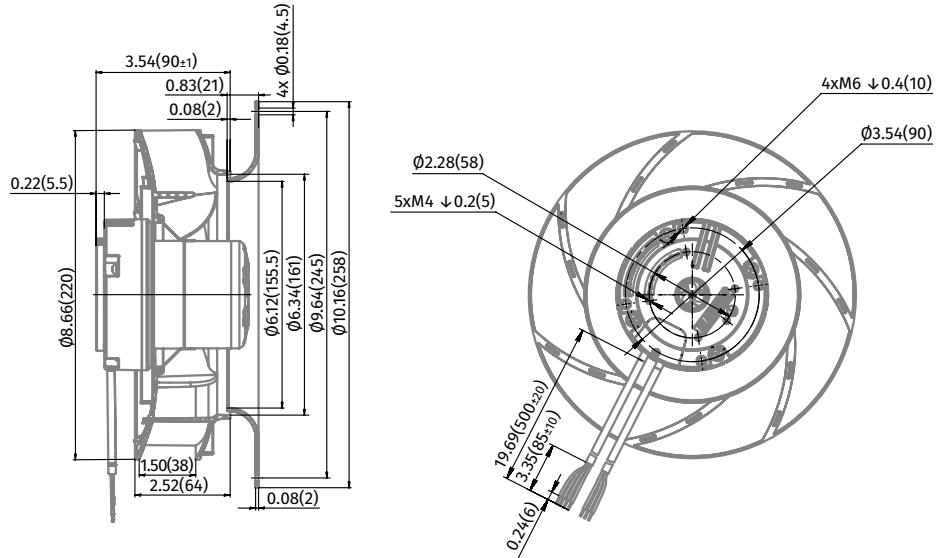

GC-B220C-EC-01

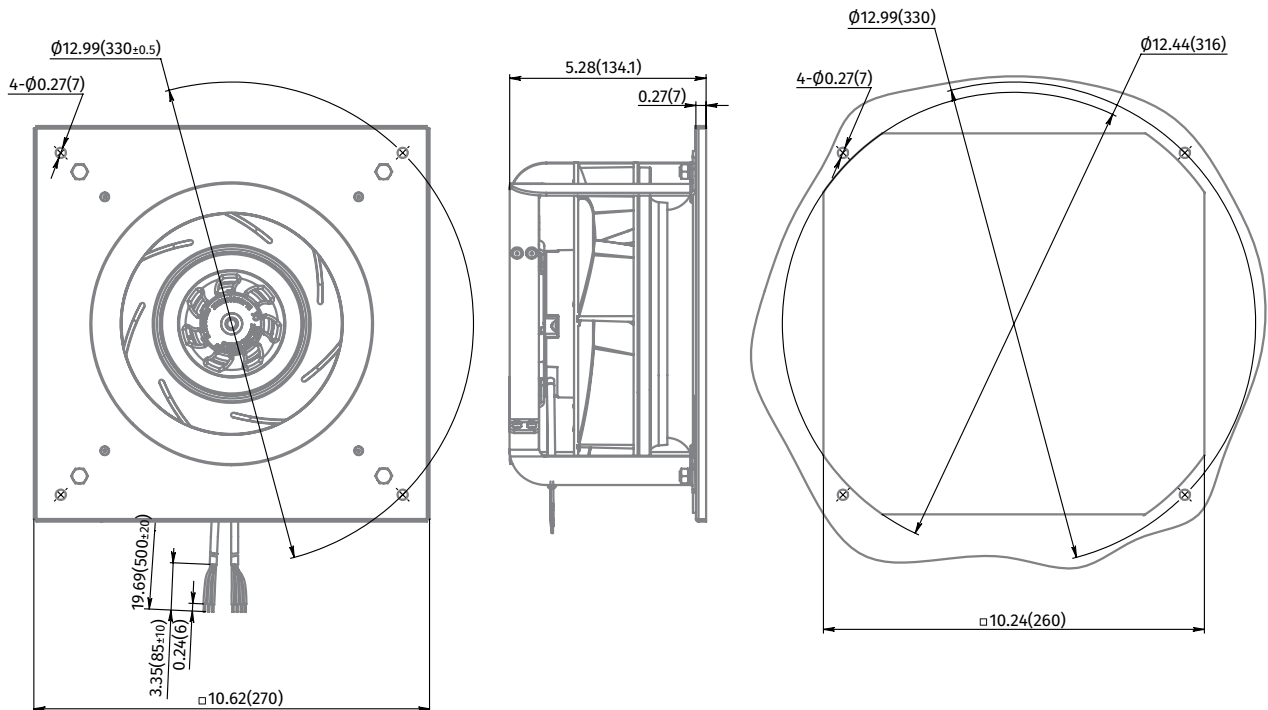

Ø 220 mm, BACKWARD CURVED

EC CENTRIFUGAL FAN

Ø 133

Ø 175

Ø 190

Ø 220

Ø 225

Ø 250

Ø 190

Ø 220

Ø 250

Ø 225 mm, BACKWARD CURVED

EC CENTRIFUGAL FAN

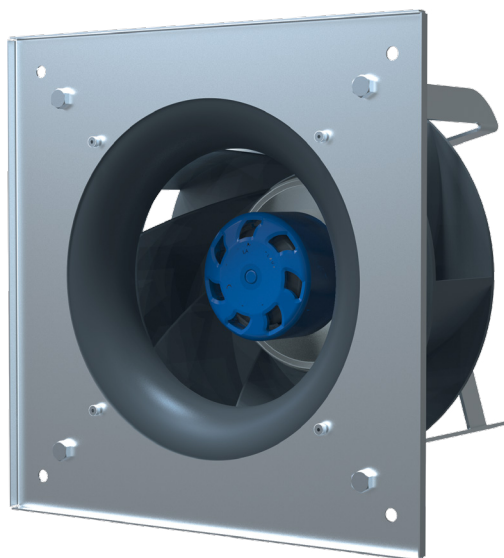

Features

- **Materials:** Impeller – PA6+GF20
Inlet ring – PA6+GF20
Housing – sheet steel, painted grey
- **Direction of rotation:** clockwise, seen on rotor
- **Type of protection:** IP55
- **Insulation class:** B
- **Mode of operation:** S1
- **Bearing:** ball bearings
- **Motor protection:** fuse



Technical data

Model	Perform. curve	Nominal voltage [VAC]	Frequency [Hz]	Speed [RPM]	Power input max [W]	Current max [A]	Sound pres. level [dB(A)]	Perm. amb. temp. [°C]	Electrical connection	Inlet ring
*C-B225D-EC-00	I	120	60	2160	81	1.1	62	-25 ... +60	Type "E"/p. 37	p.36
*C-B225D-EC-01	II	120	60	2930	175	2.3	72	-25 ... +60	Type "E"/p. 37	p.36

PERFORMANCE CURVES

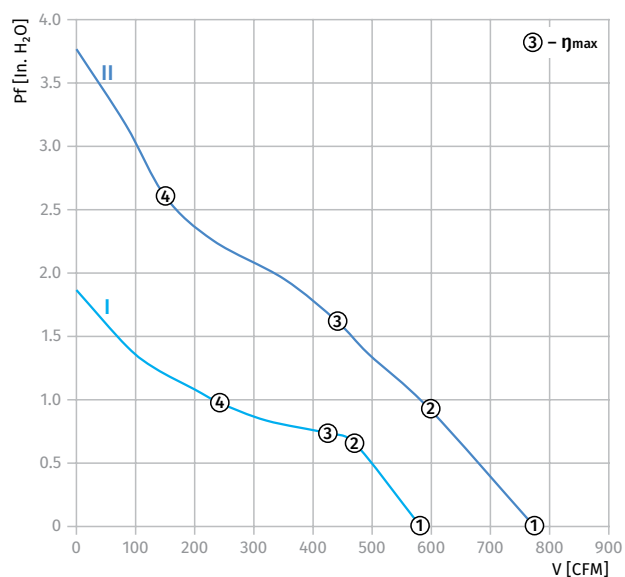

Curve	Point	n [RPM]	Pi [W]	I [A]
I	1	2304	81.7	1.093
	2	2184	81.5	1.100
	3	2160	81.3	1.103
	4	2136	81.1	1.107
II	1	3100	174.78	2.303
	2	3100	174.50	2.304
	3	2930	173.90	2.302
	4	3280	173.96	2.304

Ø 225 MM, BACKWARD CURVED

EC CENTRIFUGAL FAN

Overall Dimensions



Centrifugal Fan	Weight [kg]
BC-B225D-EC-00	1.3
BC-B225D-EC-01	1.83



Centrifugal Fan with Plug Fan	Weight [kg]
GC-B225D-EC-00	2.21
GC-B225D-EC-01	2.74

BC-B225D-EC-00

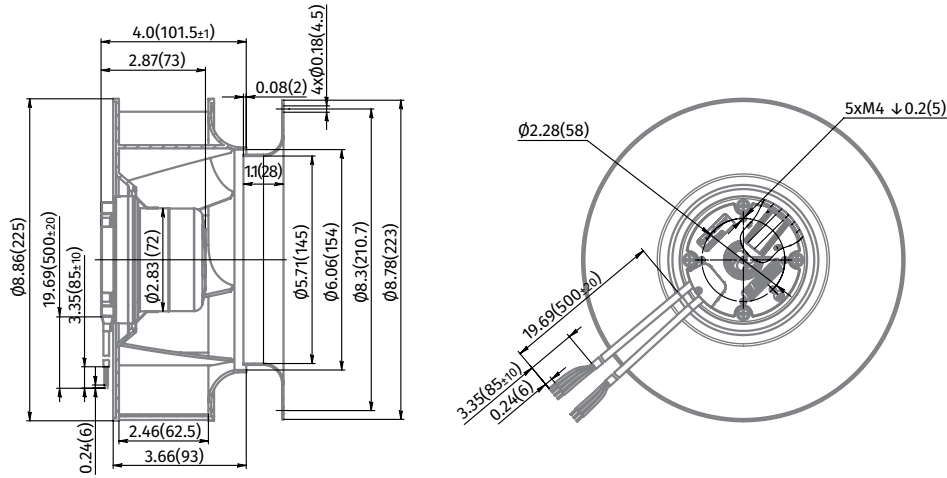

GC-B225D-EC-00

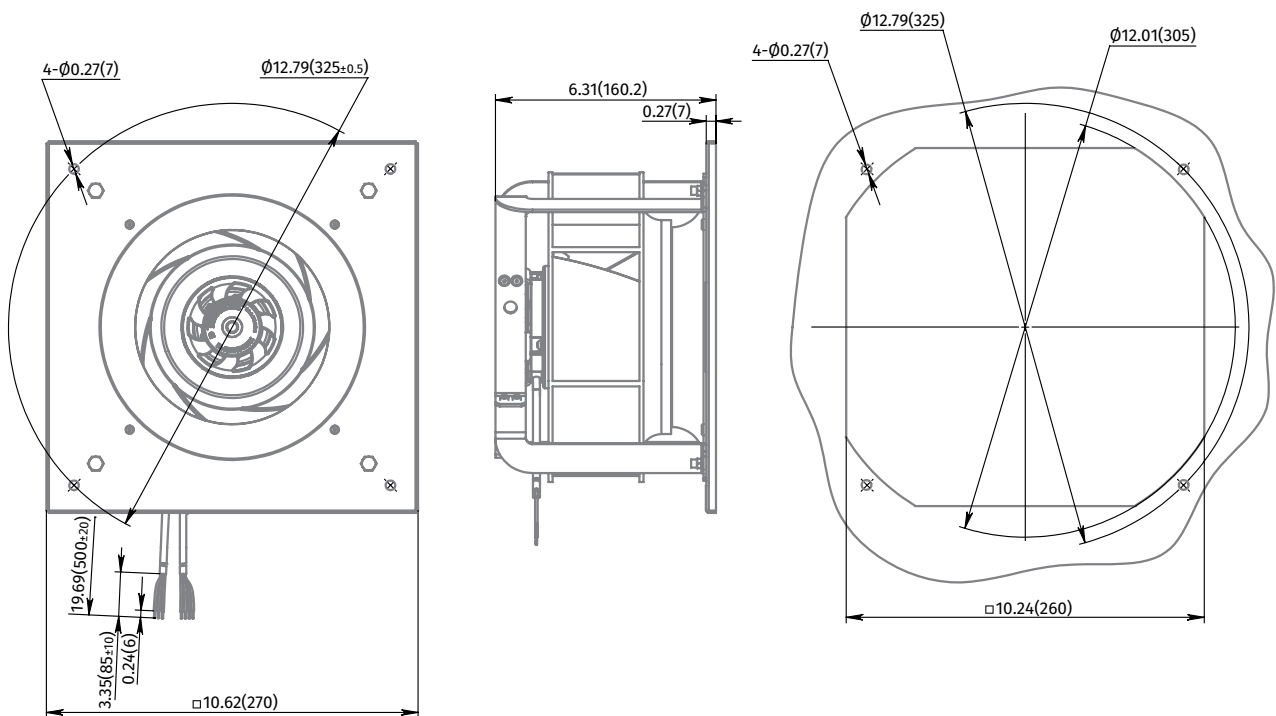

Ø 225 MM, BACKWARD CURVED

EC CENTRIFUGAL FAN

BC-B225D-EC-01

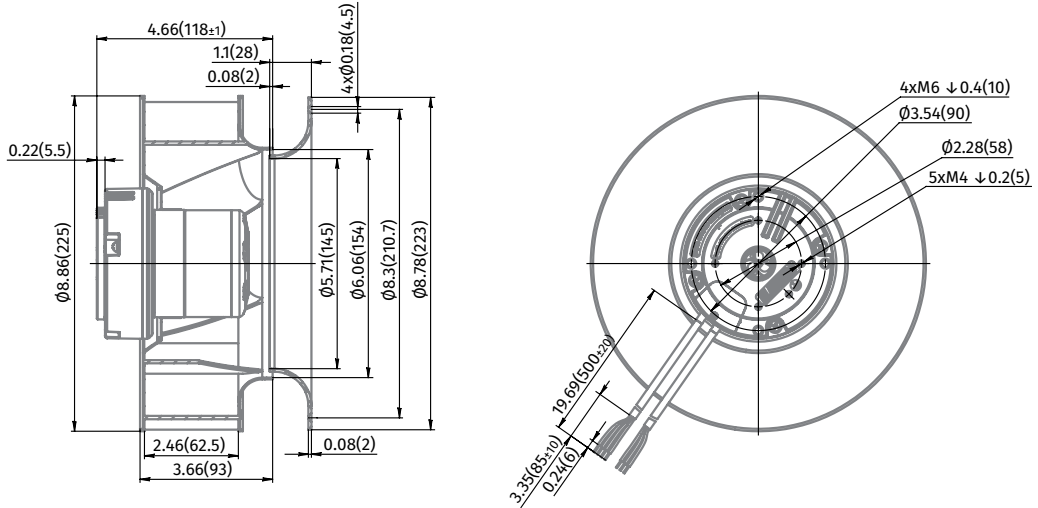

GC-B225D-EC-01

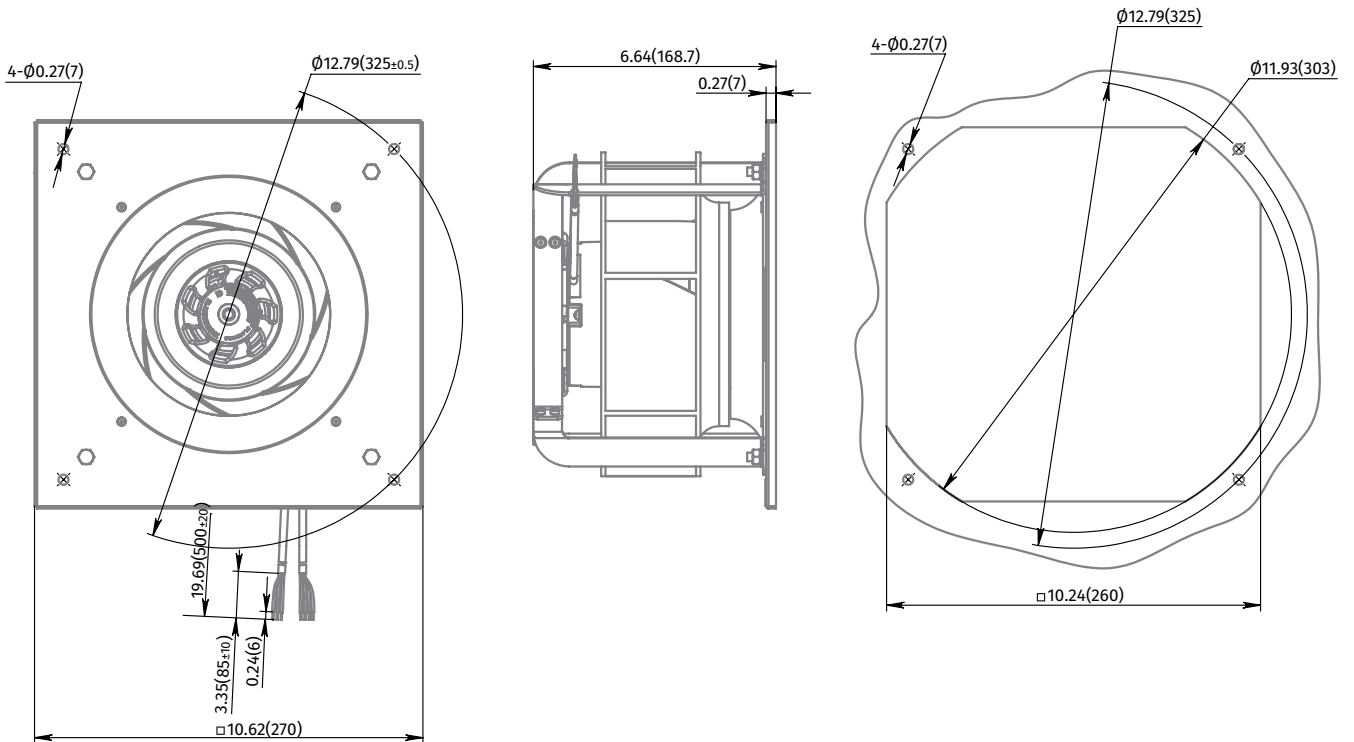

Ø 225 mm, BACKWARD CURVED

EC CENTRIFUGAL FAN

Ø 133

Ø 175

Ø 190

Ø 220

Ø 225

Ø 250

Ø 190

Ø 220

Ø 250

Ø 250 mm, BACKWARD CURVED

EC CENTRIFUGAL FAN

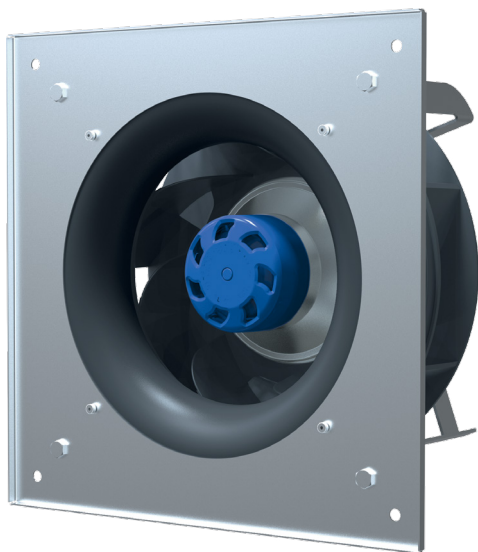

Features

- **Materials:** Impeller – PA6+GF20
Inlet ring – PA6+GF20
Housing – sheet steel, painted grey
- **Direction of rotation:** clockwise, seen on rotor
- **Type of protection:** IP55
- **Insulation class:** B
- **Mode of operation:** S1
- **Bearing:** ball bearings
- **Motor protection:** fuse



Technical data

Model	Perform. curve	Nominal voltage [VAC]	Frequency [Hz]	Speed [RPM]	Power input max [W]	Current max [A]	Sound pres. level [dB(A)]	Perm. amb. temp. [°C]	Electrical connection	Inlet ring
*C-B250B-EC-00	I	120	60	1716	85	1.1	72	-25 ... +60	Type "E"/p. 37	p.36
*C-B250B-EC-01	II	120	60	2400	173	2.2	73	-25 ... +60	Type "E"/p. 37	p.36

PERFORMANCE CURVES

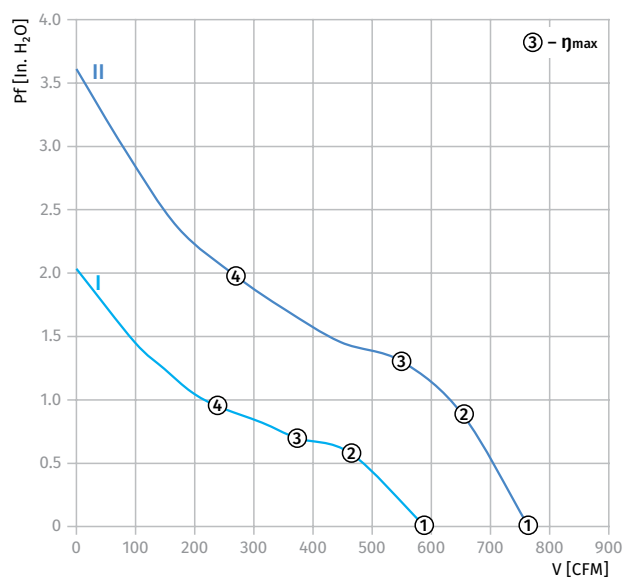

Curve	Point	n [RPM]	Pi [W]	I [A]
I	1	1956	81.9	1.115
	2	1752	75.8	1.046
	3	1716	75.3	1.040
	4	1836	78.7	1.083
II	1	2628	173.8	2.192
	2	2496	173.5	2.190
	3	2400	173.2	2.188
	4	2604	172.8	2.187

Ø 250 MM, BACKWARD CURVED

EC CENTRIFUGAL FAN

Overall Dimensions

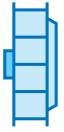

Centrifugal Fan	Weight [kg]
BC-B250B-EC-00	1.3
BC-B250B-EC-01	1.85



Centrifugal Fan with Plug Fan	Weight [kg]
GC-B250B-EC-00	2.37
GC-B250B-EC-01	2.92

BC-B250B-EC-00

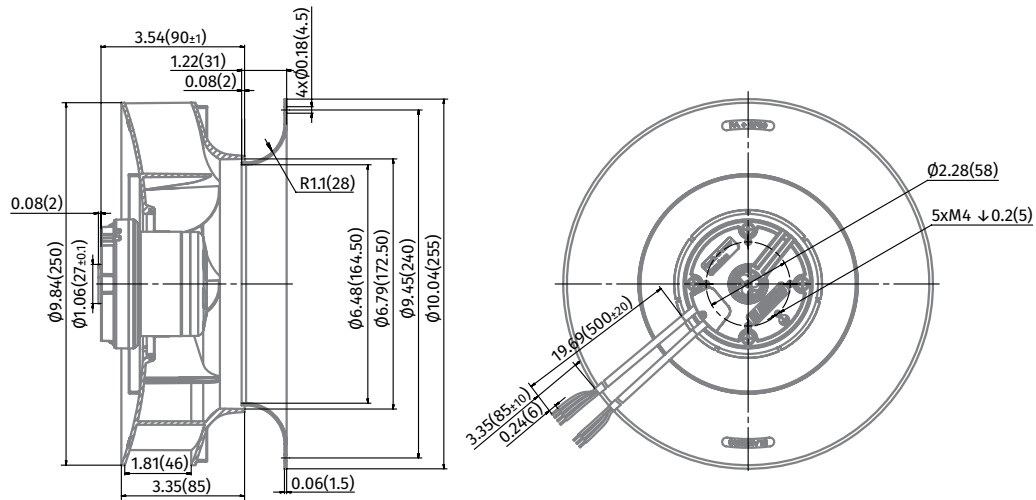

GC-B250B-EC-00

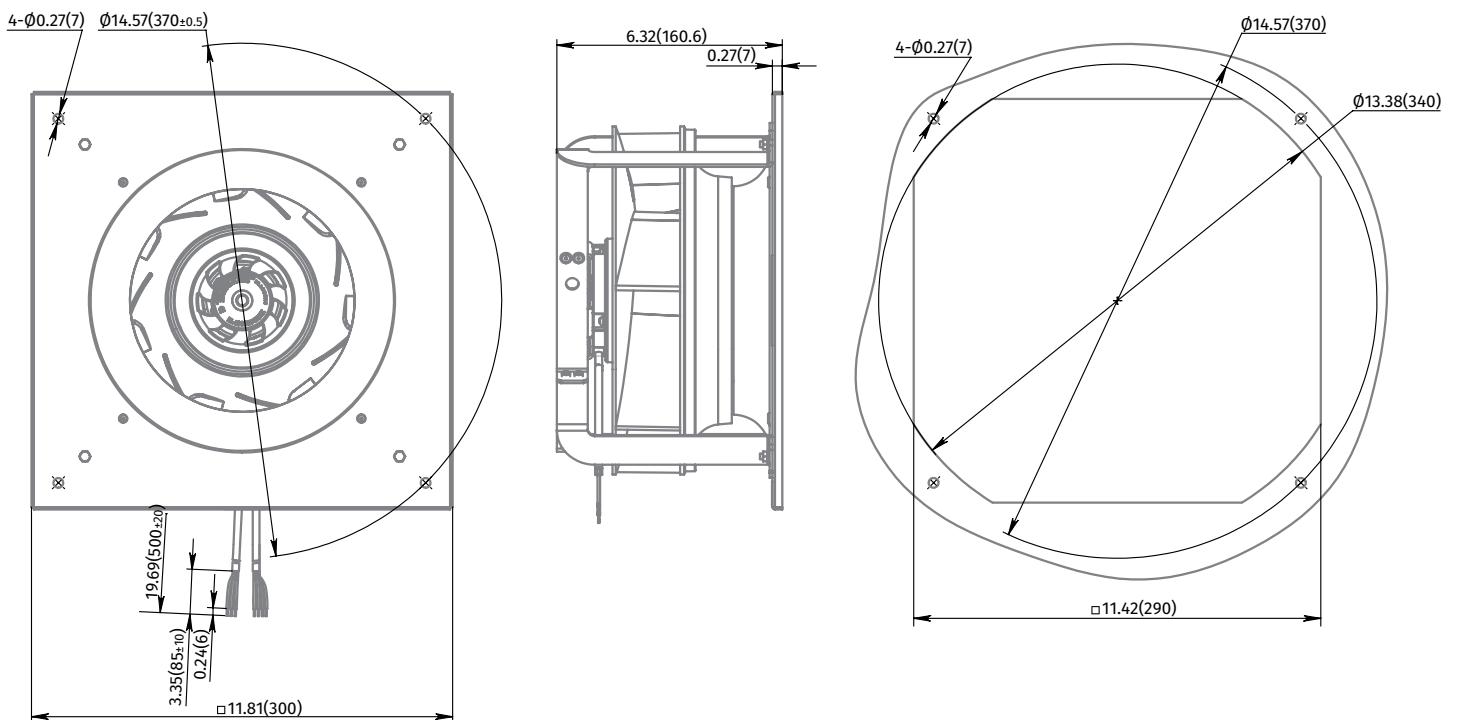

Ø 250 mm, BACKWARD CURVED

EC CENTRIFUGAL FAN

BC-B250B-EC-01

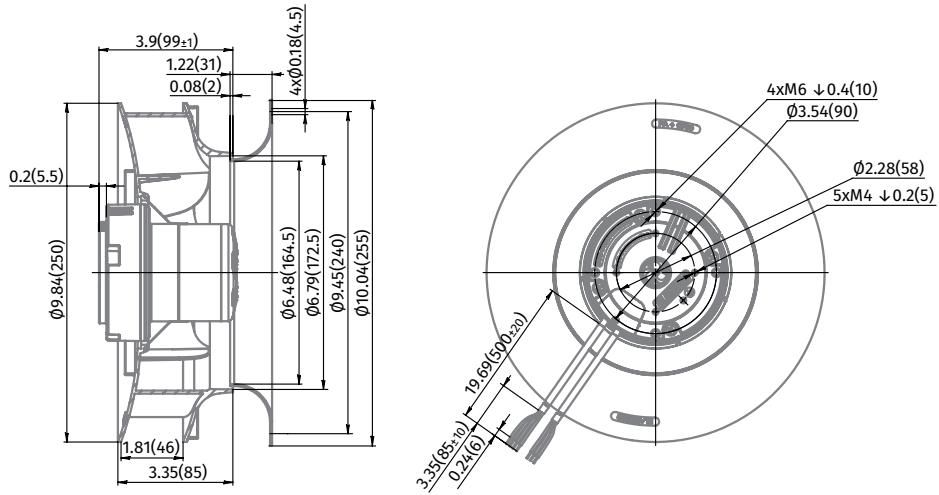

GC-B250B-EC-01

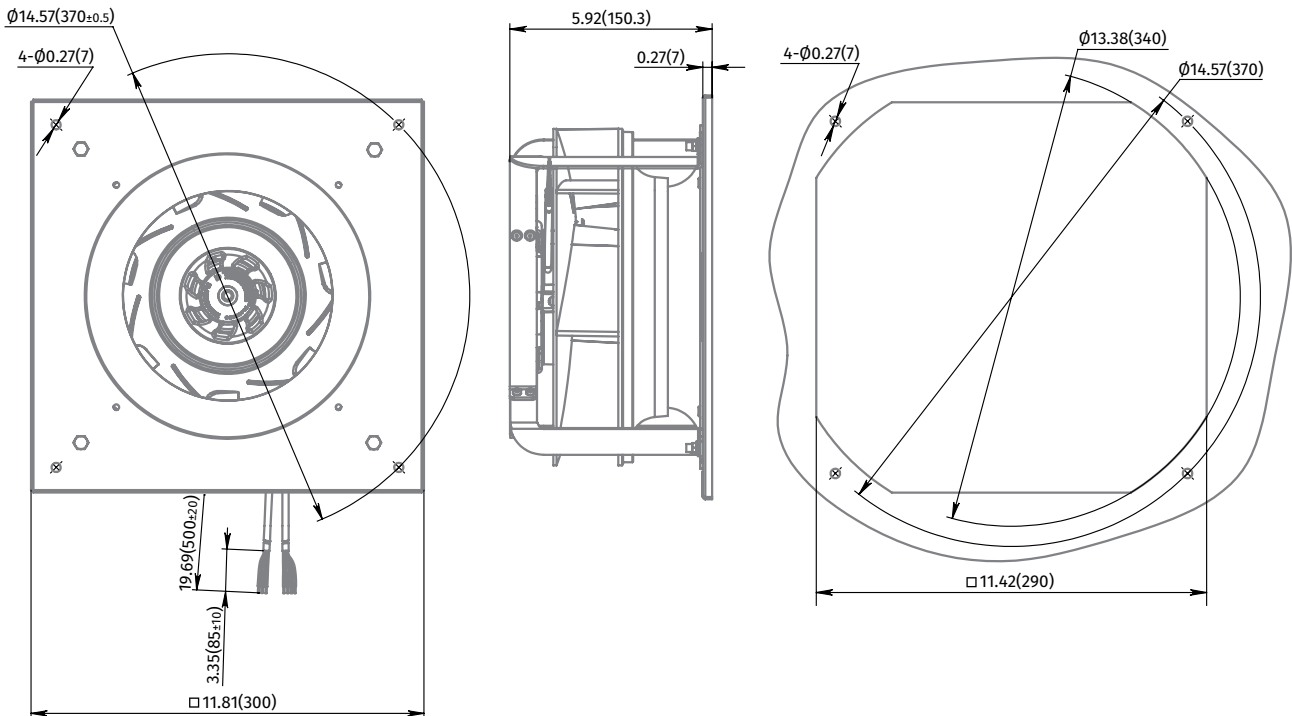

AC CENTRIFUGAL FANS

Ø 190 22

Ø 220 24

Ø 250 26

Ø 190 MM, BACKWARD CURVED

AC CENTRIFUGAL FAN



Features

- **Materials:** Impeller – PA6+GF20
Inlet ring – PA6+GF20
Housing – sheet steel, painted grey
- **Direction of rotation:** clockwise, seen on rotor
- **Type of protection:** IP44
- **Insulation class:** B
- **Mode of operation:** continuous operation (S1)
- **Bearing:** ball bearings
- **Motor protection:** self-resetting TOP wired internally



Technical data

Model	Perform. curve	Nominal voltage [VAC]	Frequency [Hz]	Speed [RPM]	Power input max [W]	Current max [A]	Sound pres. level [dB(A)]	Perm. amb. temp. [°C]	Capacitor / Capacitor voltage [µF] / [VDB]	Electrical connection	Inlet ring
*L-B190A-2C-A01-01	I	120	60	2750	70	0.6	62	-25 ... +50	6/250	Type "A"/p. 37	p.36
*L-B190A-2C-A02-01	II	120	60	2870	90	0.75	64	-25 ... +50	8/250	Type "A"/p. 37	p.36

PERFORMANCE CURVES

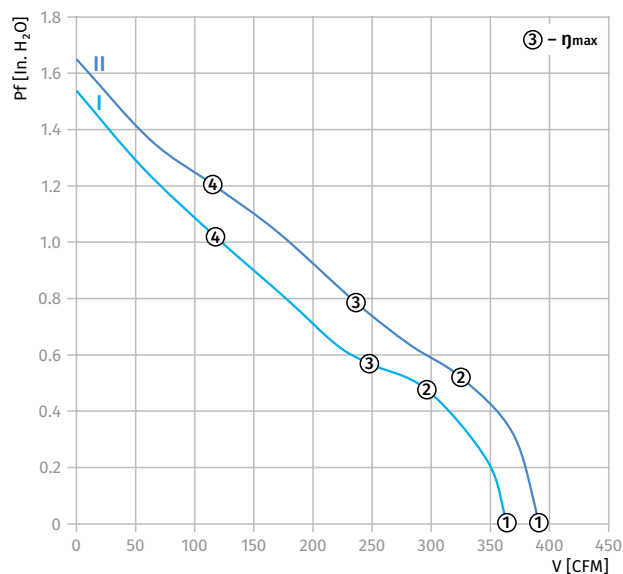

Curve	Point	n [RPM]	Pi [W]	I [A]
I	1	2760	71.6	0.597
	2	2676	74.1	0.618
	3	2628	75.3	0.628
	4	2724	72.6	0.606
II	1	2976	86.6	0.728
	2	2892	87.9	0.739
	3	2832	91.3	0.765
	4	2940	85.6	0.720

Ø 190 MM, BACKWARD CURVED

AC CENTRIFUGAL FAN

Overall Dimmensions

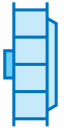

Centrifugal Fan	Weight [kg]
BL-B190A-2C-A01-01	1.31
BL-B190A-2C-A02-01	1.34



Centrifugal Fan with Plug Fan	Weight [kg]
GL-B190A-2C-A01-01	2.16
GL-B190A-2C-A02-01	2.19

BL-B190A-2C-A01-01, BL-B190A-2C-A02-01

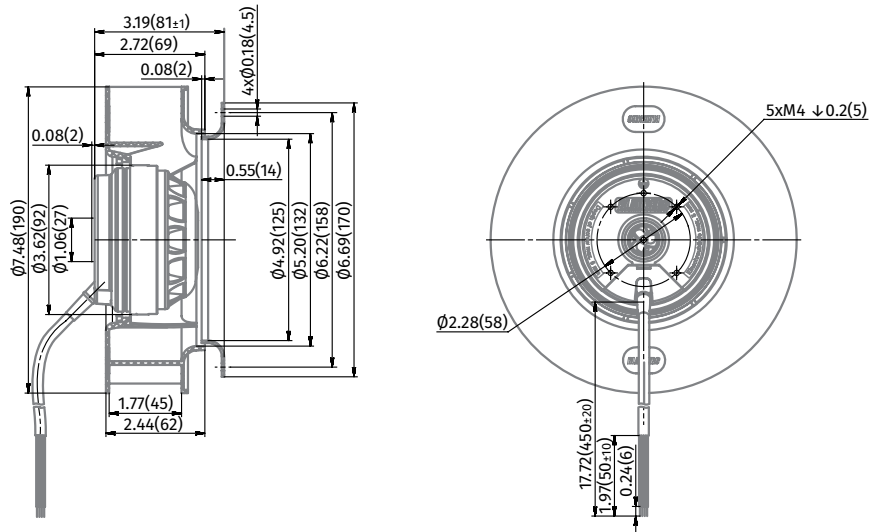

GL-B190A-2C-A01-01, GL-B190A-2C-A02-01

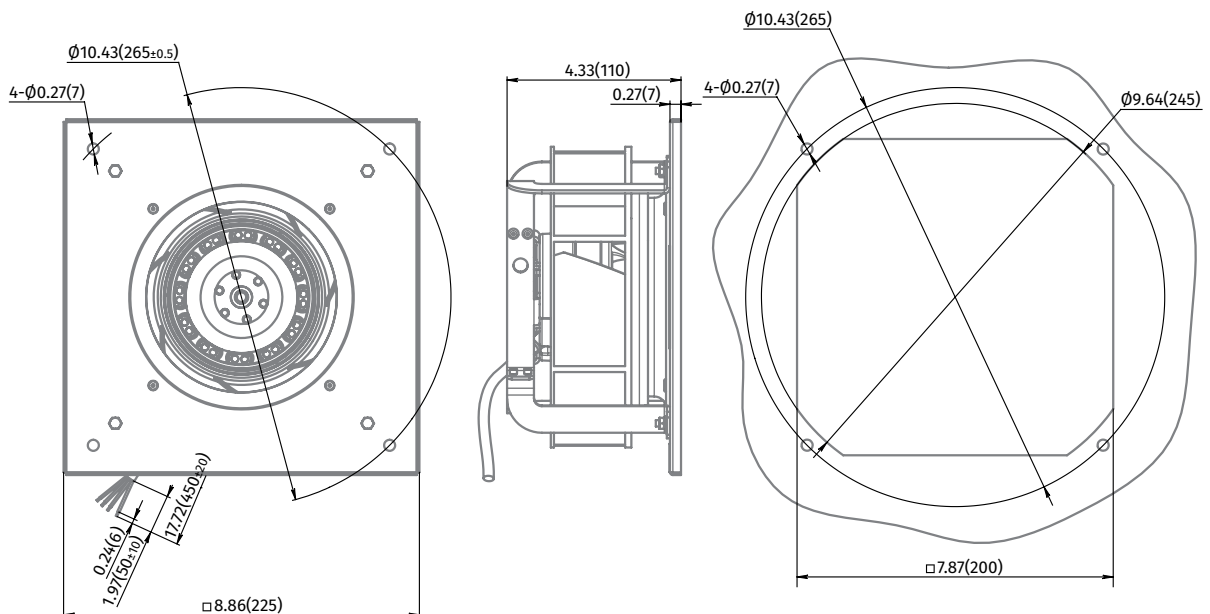

Ø 220 MM, BACKWARD CURVED

AC CENTRIFUGAL FAN



Features

- **Materials:** Impeller – PA6+GF20
Inlet ring – PA6+GF20
Housing – sheet steel, painted grey
- **Direction of rotation:** clockwise, seen on rotor
- **Type of protection:** IP44
- **Insulation class:** B
- **Mode of operation:** continuous operation (S1)
- **Bearing:** ball bearings
- **Motor protection:** self-resetting TOP wired internally



Technical data

Model	Perform. curve	Nominal voltage [VAC]	Frequency [Hz]	Speed [RPM]	Power input max [W]	Current max [A]	Sound pres. level [dB(A)]	Perm. amb. temp. [°C]	Capacitor / Capacitor voltage [µF] / [VDB]	Electrical connection	Inlet ring
*L-B220B-2C-A01-01	I	120	60	2200	115	0.97	69	-25 ... +50	8/250	Type "A"/p. 37	p.36

PERFORMANCE CURVES

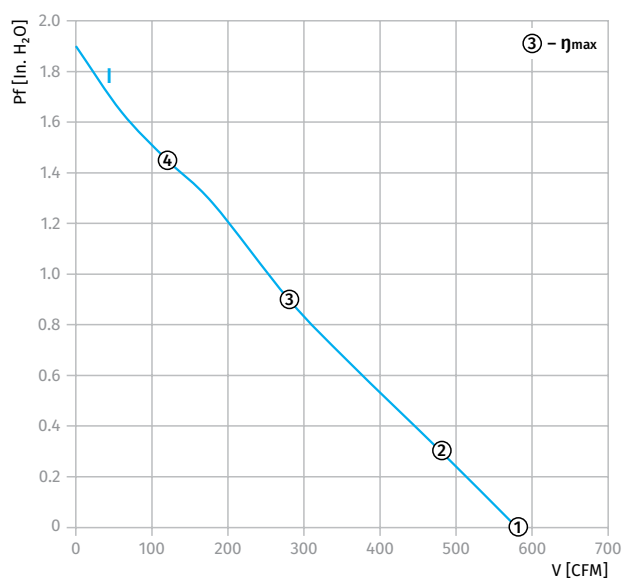

Curve	Point	n [RPM]	Pi [W]	I [A]
I	1	2390	111.61	0.970
	2	2130	115.37	0.979
	3	2200	115.31	0.977
	4	2380	113.06	0.976

Ø 220 MM, BACKWARD CURVED

AC CENTRIFUGAL FAN

Overall Dimensions



Centrifugal Fan	Weight [kg]
BL-B220B-2C-A01-01	1.38



Centrifugal Fan with Plug Fan	Weight [kg]
GL-B220B-2C-A01-01	2.23

BL-B220B-2C-A01-01

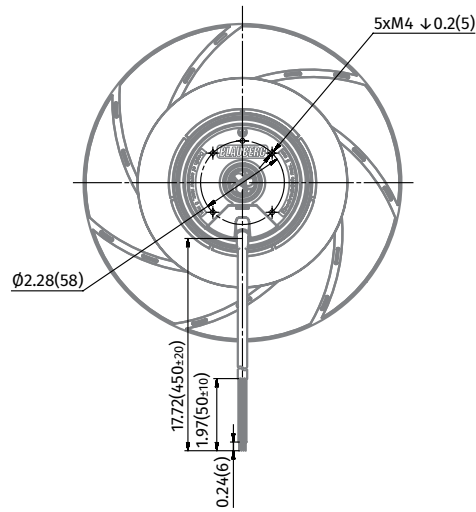
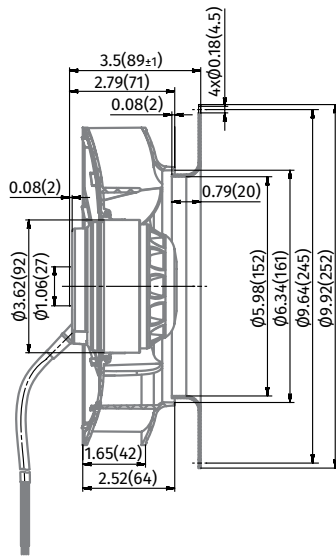

GL-B220B-2C-A01-01

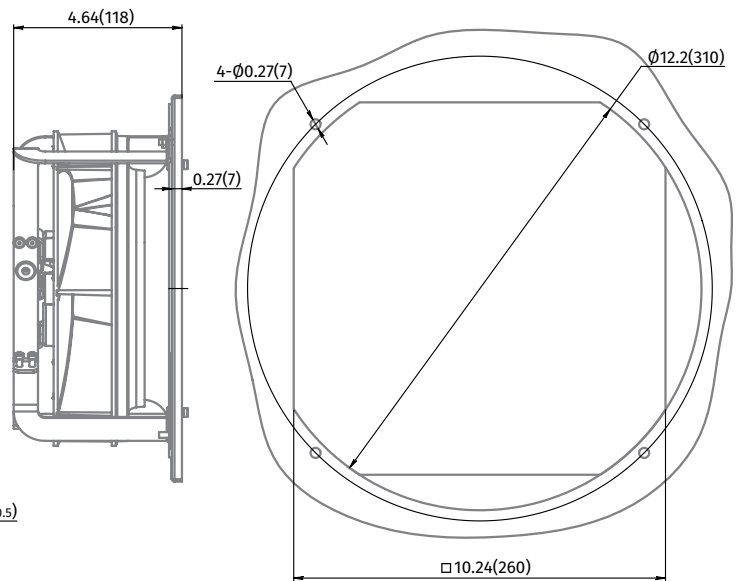
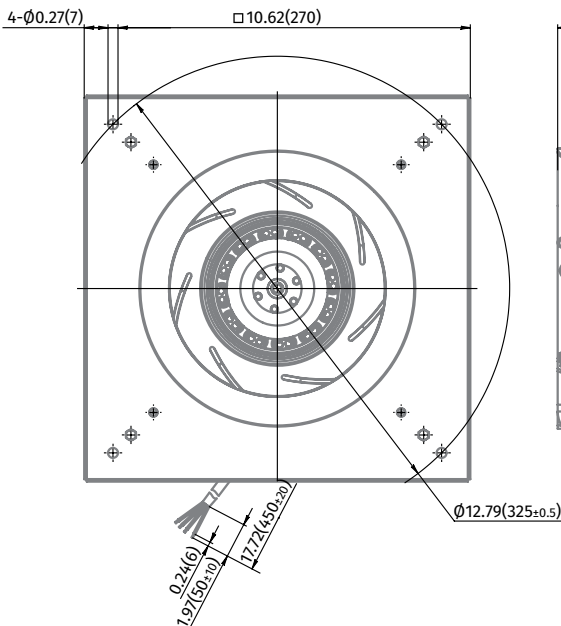

Ø 250 mm, BACKWARD CURVED

AC CENTRIFUGAL FAN

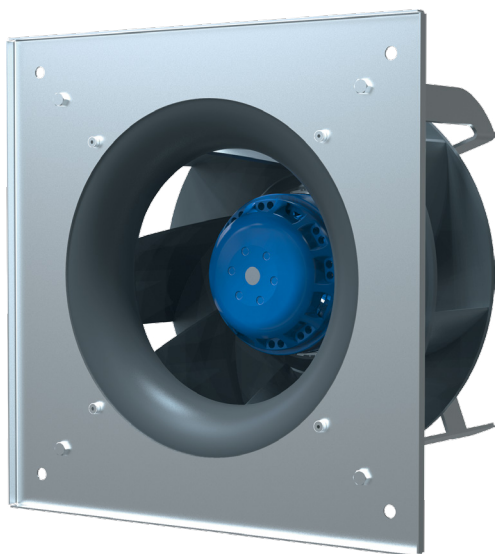

Features

- **Materials:** Impeller – PA6+GF20+galvanized steel
Inlet ring– PA6+GF20
Housing – sheet steel, painted grey
- **Direction of rotation:** clockwise, seen on rotor
- **Type of protection:** IP44
- **Insulation class:** B
- **Mode of operation:** continuous operation (S1)
- **Bearing:** ball bearings
- **Motor protection:** self-resetting TOP wired internally



Technical data

Model	Perform. curve	Nominal voltage [VAC]	Frequency [Hz]	Speed [RPM]	Power input max [W]	Current max [A]	Sound pres. level [dB(A)]	Perm. amb. temp. [°C]	Capacitor / Capacitor voltage [µF] / [VDB]	Electrical connection	Inlet ring
*L-B250A-2C-D01-01	I	120	60	3000	310	2.7	70	-25 ... +50	25/250	Type "A"/p. 37	p.36

PERFORMANCE CURVES

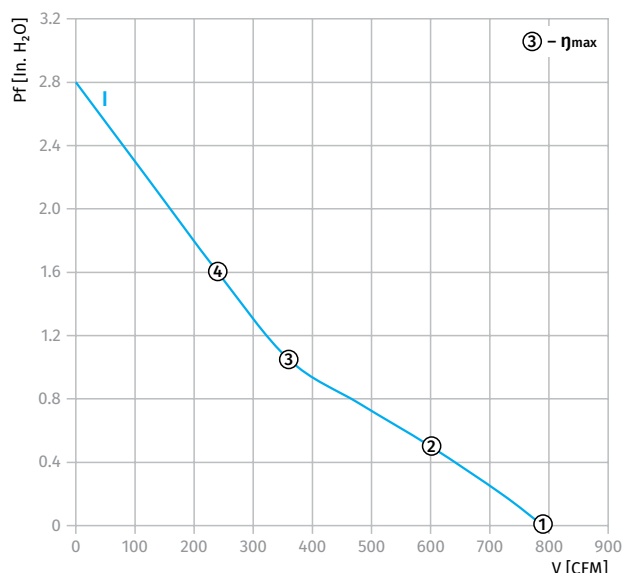

Curve	Point	n [RPM]	Pi [W]	I [A]
I	1	3300	296.61	2.712
	2	3220	302.37	2.749
	3	3000	310.31	2.787
	4	2900	310.06	2.786

Ø 250 MM, BACKWARD CURVED

AC CENTRIFUGAL FAN

Overall Dimmensions



Centrifugal Fan	Weight [kg]
BL-B250A-2C-D01-01	2.48



Centrifugal Fan with Plug Fan	Weight [kg]
GL-B250A-2C-D01-01	3.55

BL-B250A-2C-D01-01

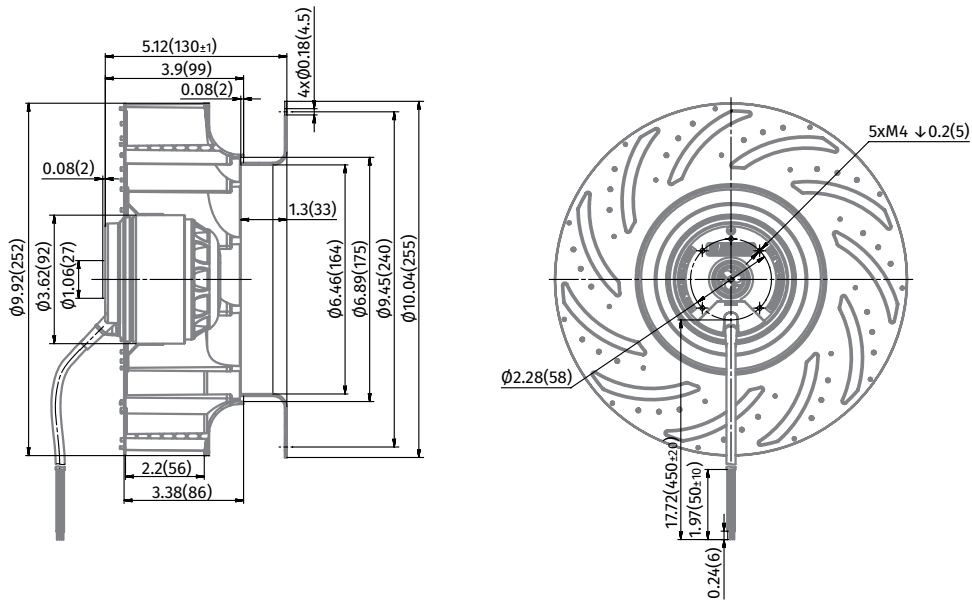

GL-B250A-2C-D01-01

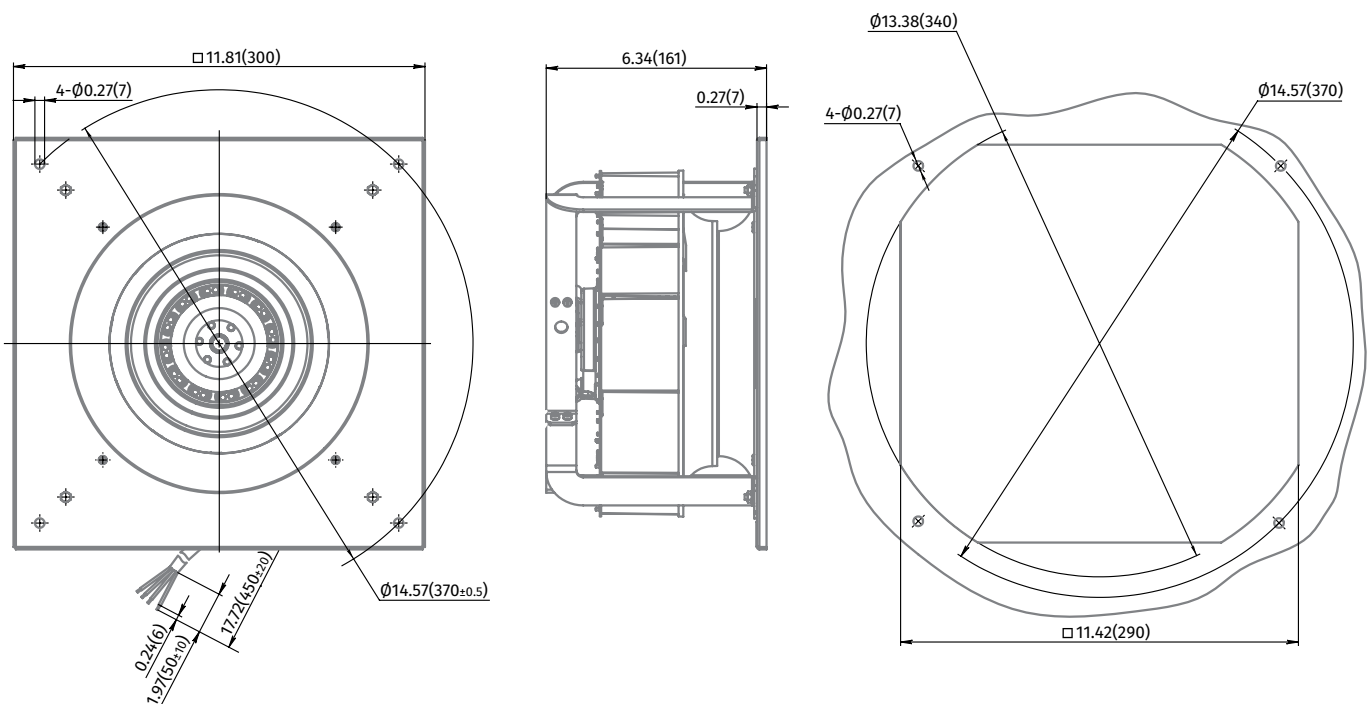

INLET RINGS

Inlet rings IR-PA series

- For backward curved blade impellers
- Made of high quality plastic

OVERALL DIMENSIONS [IN. (MM)]

BLAUBERG Inlet ring	BLAUBERG Impeller size	A	B	C	D	RE	h	t	g	Fig.
IR 190BC PA	7.49(190)	6.77(172)	6.22(158)	4.74(120.5)	4.92(125.5)	0.39(10)	0.63(15.9)	0.10(2.5)	0.18(4.5)	1
IR 220BC PA	8.66(220)	10.16(258)	9.64(245)	5.87(149)	6.02(153)	0.79(20)	0.83(21)	0.08(2.0)	0.18(4.5)	2
IR 225BC PA	8.86(225)	8.78(223)	8.3(210.7)	5.55(141)	5.71(145)	0.98(25)	1.1(28)	0.08(2.0)	0.18(4.5)	1
IR 250BC PA	9.84(250)	10.04(255)	9.45(240)	6.3(160)	6.46(164)	1.1(28)	1.22(31)	0.08(2.0)	0.18(4.5)	1

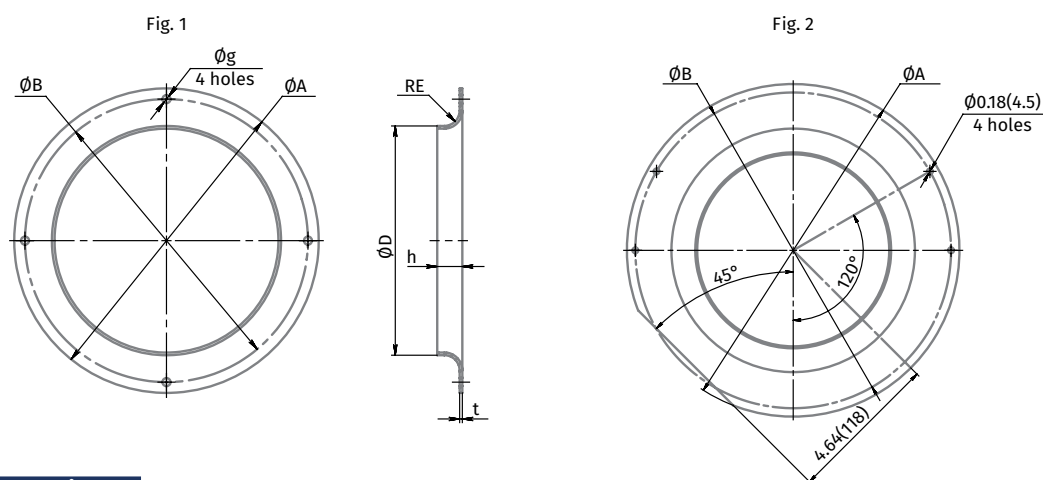

Inlet rings IR-GS series

- For backward curved blade impellers
- Made of galvanized steel

OVERALL DIMENSIONS [IN. (MM)]

BLAUBERG Inlet ring	BLAUBERG Impeller size	DA	E	DE	Re	F-ØG	h	t
IR 190BC GS	7.49(190)	6.69(170)	6.22(158)	4.9(125)	0.39(10)	4-Ø0.18(4.5)	0.55(14)	0.02(0.6)
IR 220BC GS	8.66(220)	9.92(252)	9.29(236)	5.98(152)	0.87(22)	4-Ø0.18(4.5)	0.83(21)	0.02(0.6)
IR 225BC GS	8.86(225)	8.78(223)	8.3(210.7)	5.71(145)	0.83(21)	4-Ø0.18(4.5)	1.1(28)	0.06(1.5)
IR 250BC GS	9.84(250)	10.04(255)	9.45(240)	6.46(164)	0.71(18)	4-Ø0.18(4.5)	1.3(33)	0.06(1.5)

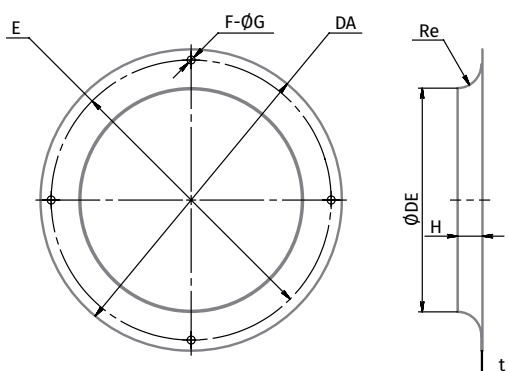

ELECTRICAL CONNECTION DIAGRAM

Type "A"

- U1 Blue
- U2 Black
- Z1 Brown
- PE Green/Yellow

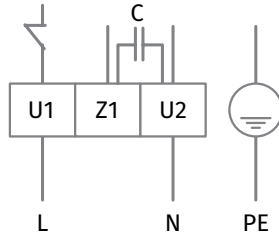

Type "E"

- U1 Brown
- U2 Blue
- PE Green/Yellow
- U4 Red
- U5 Yellow
- U6 White
- U7 Blue

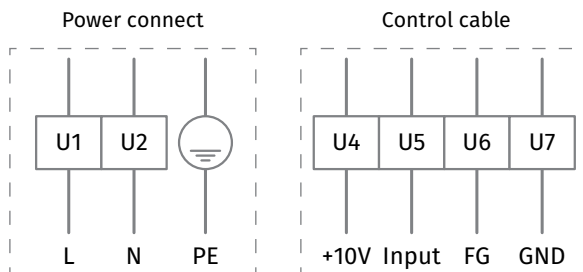

Blauberg Group
Aidenbachstr. 52
D-81379 Munich
Tel.: +49 (0)89 231 66 620
Fax: +49 (0)89 780 69 521

sales@blauberg-motoren.com
blauberg-motoren.com

Technical changes reserved.
Illustrations and texts are non-binding.

01/2018